

# Inspiron 16 5645

## Owner's Manual

## Notes, cautions, and warnings

 **NOTE:** A NOTE indicates important information that helps you make better use of your product.

 **CAUTION:** A CAUTION indicates either potential damage to hardware or loss of data and tells you how to avoid the problem.

 **WARNING:** A WARNING indicates a potential for property damage, personal injury, or death.

<b>Chapter 1: Views of Inspiron 16 5645</b>	<b>7</b>
Right	7
Left	7
Top	8
Front	9
Bottom	10
Service Tag	11
Battery charge and status light	11
<b>Chapter 2: Set up your Inspiron 16 5645</b>	<b>12</b>
<b>Chapter 3: Specifications of Inspiron 16 5645</b>	<b>14</b>
Dimensions and weight	14
Processor	14
Chipset	15
Operating system	15
Memory	15
External ports	16
Internal slots	16
Wireless module	16
Audio	17
Storage	17
Media-card reader	18
Keyboard	18
Keyboard function keys	19
Camera	20
Touchpad	20
Power adapter	21
Battery	22
Display	23
Fingerprint reader (optional)	24
Sensor	24
GPU—Integrated	24
External display support	24
Hardware security	25
Operating and storage environment	25
Dell support policy	25
ComfortView	25
ComfortView Plus	26
<b>Chapter 4: Working inside your computer</b>	<b>27</b>
Safety instructions	27
Before working inside your computer	27
Safety precautions	28

Electrostatic discharge—ESD protection.....	28
ESD Field Service kit .....	29
Transporting sensitive components.....	30
After working inside your computer.....	30
BitLocker.....	30
Recommended tools.....	30
Screw list.....	30
Major components of Inspiron 16 5645.....	32
<b>Chapter 5: Removing and installing Customer Replaceable Units (CRUs).....</b>	<b>34</b>
Base cover.....	34
Removing the base cover.....	34
Installing the base cover .....	37
Memory module.....	40
Removing the memory module .....	40
Installing the memory module .....	41
M.2 solid state drive.....	42
Removing the solid-state drive .....	42
Installing the solid-state drive .....	43
Wireless card.....	44
Removing the wireless card .....	44
Installing the wireless card .....	45
Speakers.....	46
Removing the speakers .....	46
Installing the speakers .....	48
Fan.....	50
Removing the fan .....	50
Installing the fan .....	51
<b>Chapter 6: Removing and installing Field Replaceable Units (FRUs).....</b>	<b>53</b>
Battery.....	53
Rechargeable Li-ion battery precautions.....	53
Removing the battery .....	53
Disconnecting the battery cable .....	54
Connecting the battery cable .....	56
Installing the battery .....	57
Heat sink.....	59
Removing the heat sink .....	59
Installing the heat sink .....	60
Touchpad.....	61
Removing the touchpad assembly .....	61
Installing the touchpad assembly .....	62
Display assembly.....	64
Removing the display assembly .....	64
Installing the display assembly .....	65
I/O-board cable .....	67
Removing the I/O-board cable.....	67
Installing the I/O-board cable.....	68
I/O board.....	69

Removing the I/O board .....	69
Installing the I/O board .....	70
Power button.....	72
Removing the power button .....	72
Installing the power button .....	73
Power button with optional fingerprint reader.....	74
Removing the power button with optional fingerprint reader .....	74
Installing the power button with optional fingerprint reader .....	75
Power-adapter port.....	76
Removing the power-adapter port .....	76
Installing the power-adapter port .....	77
System board.....	78
Removing the system board .....	78
Installing the system board .....	82
Palm-rest and keyboard assembly.....	85
Removing the palm-rest and keyboard assembly .....	85
Installing the palm-rest and keyboard assembly .....	87
<b>Chapter 7: Software.....</b>	<b>89</b>
Operating system.....	89
Drivers and downloads.....	89
<b>Chapter 8: BIOS Setup.....</b>	<b>90</b>
Entering BIOS setup program.....	90
Navigation keys.....	90
F12 One Time Boot menu.....	90
System setup options.....	91
Updating the BIOS.....	96
Updating the BIOS in Windows.....	96
Updating the BIOS using the USB drive in Windows.....	96
Updating the BIOS from the F12 One Time Boot menu.....	96
System and setup password.....	97
Assigning a System Setup password.....	97
Deleting or changing an existing system setup password.....	98
Clearing BIOS (System Setup) and System passwords.....	98
<b>Chapter 9: Troubleshooting.....</b>	<b>99</b>
Handling swollen rechargeable Li-ion batteries.....	99
Locate the Service Tag or Express Service Code of your Dell computer .....	99
Dell SupportAssist Pre-boot System Performance Check diagnostics.....	100
Running the SupportAssist Pre-Boot System Performance Check.....	100
Built-in self-test (BIST).....	100
M-BIST.....	100
LCD Power rail test (L-BIST).....	101
LCD Built-in Self-Test (BIST).....	101
System-diagnostic lights.....	102
Recovering the operating system.....	102
Real-Time Clock (RTC Reset).....	103
Backup media and recovery options.....	103

Wi-Fi power cycle.....103  
Drain residual flea power (perform hard reset).....103

**Chapter 10: Getting help and contacting Dell Technologies..... 105**

# Views of Inspiron 16 5645

## Right



Figure 1. Right view

### 1. SD-card slot

Reads from and writes to the SD card. The computer supports the following card types:

- Secure Digital (SD)
- Secure Digital High Capacity (SDHC)
- Secure Digital Extended Capacity (SDXC)

### 2. Universal audio port

Connect headphones or a headset (headphone and microphone combo).

### 3. USB 3.2 Gen 1 (5 Gbps) port

Connect devices such as external storage devices and printers. Provides a data transfer speed of up to 5 Gbps.

### 4. Security-cable slot (wedge-shaped)

Connect a security cable to prevent unauthorized movement of your computer.

## Left



Figure 2. Left view

### 1. Power-adaptor port

Connect a power adapter to provide power to your computer and charge the battery.

### 2. Battery-status light

Indicates the battery-charge status.

- Solid yellow-Battery charge is low.
- Blinking yellow-Battery charge is critical.

### 3. HDMI 1.4 port

Connect to a TV, external display, or another HDMI-in enabled device. Provides video and audio output.

### 4. USB 3.2 Gen 1 (5 Gbps) port

Connect devices such as external storage devices and printers. Provides a data transfer speed of up to 5 Gbps.

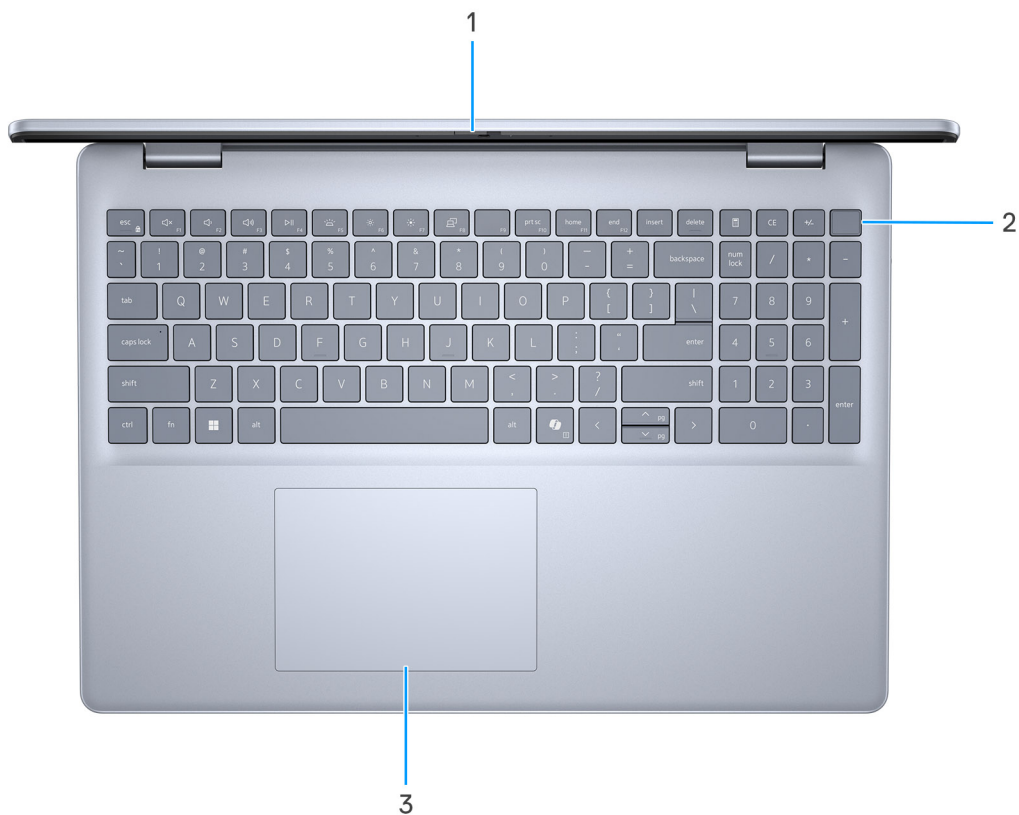
### 5. USB 3.2 Gen 2 (10 Gbps) Type-C with DisplayPort 1.4 and Power Delivery port

Connect devices such as external storage devices, printers, and external displays.

Supports Power Delivery that enables two-way power supply between devices. Provides up to 15 W power output that enables faster charging.

**NOTE:** A USB Type-C to DisplayPort adapter (sold separately) is required to connect a DisplayPort device.

## Top



**Figure 3. Top view**

#### 1. Privacy shutter

Slide the privacy shutter to cover the camera lens and protect your privacy when the camera is not in use.

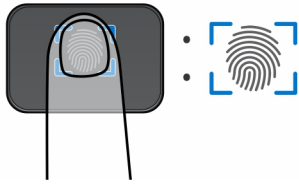
#### 2. Power button with optional fingerprint reader

Press to turn on the computer if it is turned off, in sleep state, or in Hibernate state.

When the computer is turned on, press the power button to put the computer into a sleep state.

Press and hold the power button for 10 seconds to force shut-down the computer.

If the power button has a fingerprint reader, place your finger on the power button steadily to log in.



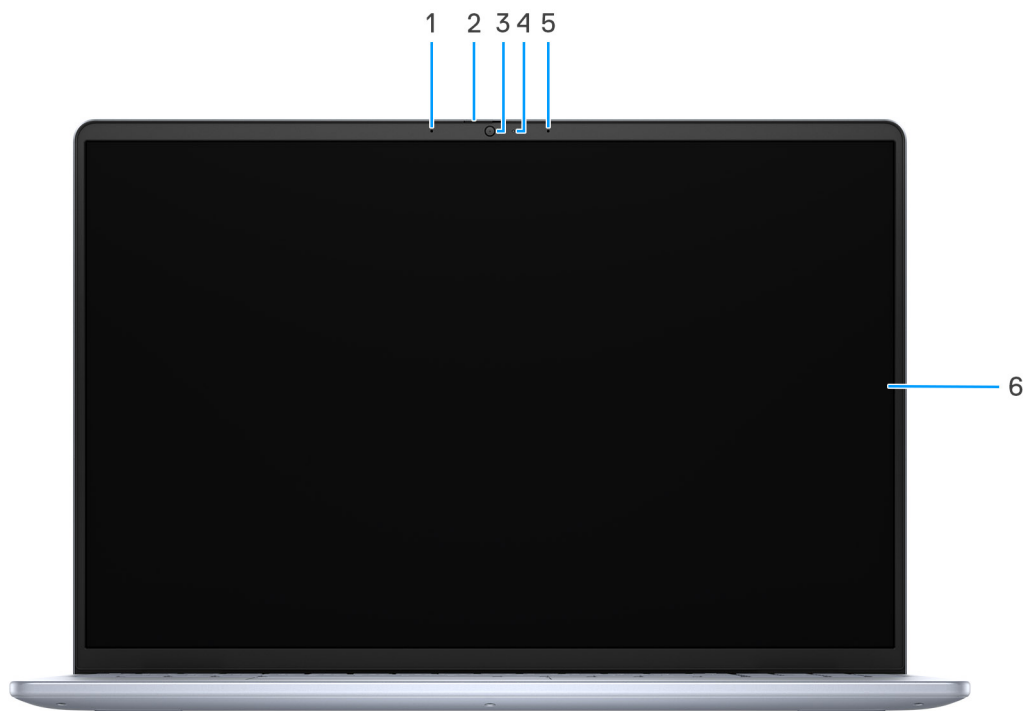
**NOTE:** The highlighted area indicates the actual active fingerprint reader area, and the image is for illustration purposes only.

**NOTE:** You can customize the power-button behavior in Windows.

### 3. Touchpad

Move your finger on the touchpad to move the mouse pointer. Tap to left-click and two fingers tap to right-click.

## Front



**Figure 4. Front view**

#### 1. Left microphone

Provides digital sound input for audio recording and voice calls.

#### 2. Privacy shutter

Slide the privacy shutter to cover the camera lens and protect your privacy when the camera is not in use.

#### 3. Camera

Enables you to video chat, capture photos, and record videos.

#### 4. Camera-status light

Turns on when the camera is in use.

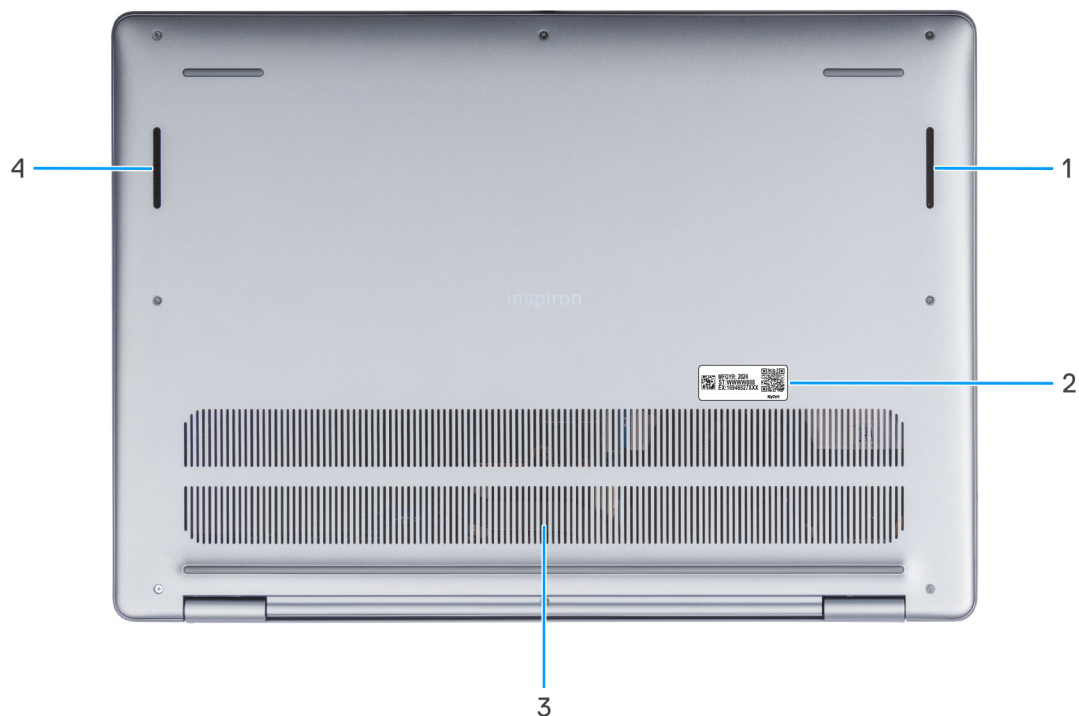
#### 5. **Right microphone**

Provides digital sound input for audio recording and voice calls.

#### 6. **Display**

Provides visual output.

## Bottom



**Figure 5. Bottom view**

#### 1. **Right speaker**

Provides audio output.

#### 2. **Service Tag label**

The Service Tag is a unique alphanumeric identifier that enables Dell service technicians to identify the hardware components in your computer and access warranty information.

#### 3. **Air vents**

Air vents provide ventilation for your computer. Clogged air vents can cause overheating and can affect your computer's performance and potentially cause hardware issues. Keep the air vents clear of obstructions and clean them regularly to prevent the build-up of dust and dirt. For more information about cleaning air vents, search for articles in the Knowledge Base Resource at [Dell Support Site](#).

#### 4. **Left speaker**

Provides audio output.

# Service Tag

The service tag is a unique alphanumeric identifier that allows Dell service technicians to identify the hardware components in your computer and access warranty information.

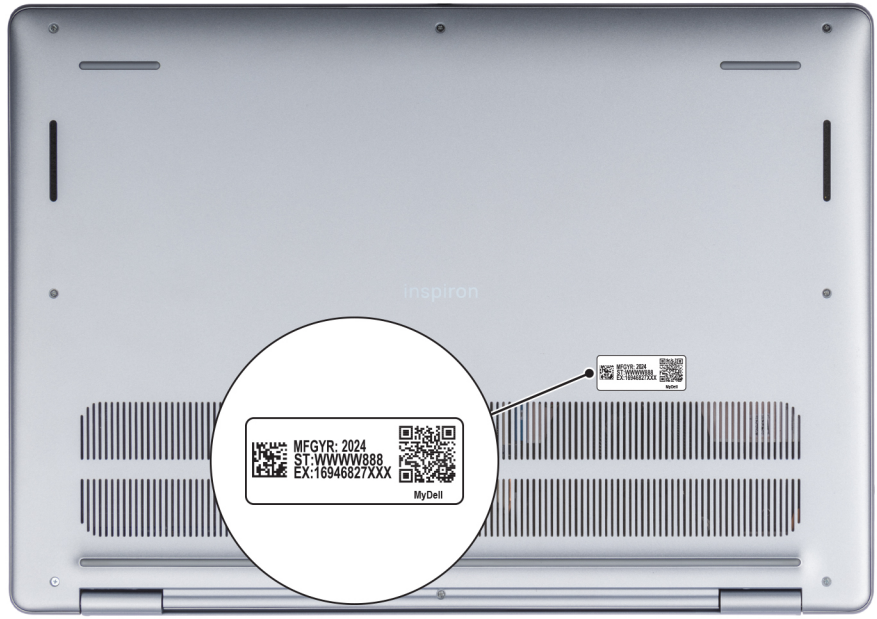


Figure 6. Service Tag location

# Battery charge and status light

The following table lists the battery charge and status light behavior of your Inspiron 16 5645.

Table 1. Battery charge and status light behavior

Power Source	LED Behavior	System Power State	Battery Charge Level
AC Adapter	Off	S0 - S5	Fully Charged
AC Adapter	Solid White	S0 - S5	< Fully Charged
Battery	Off	S0 - S5	11-100%
Battery	Solid Amber (590+/-3 nm)	S0 - S5	< 10%

- S0 (ON) - System is turned on.
- S4 (Hibernate) - The system consumes the least power compared to all other sleep states. The system is almost at an OFF state, except for a trickle power. The context data is written to a hard drive.
- S5 (OFF) - The system is in a shutdown state.

# Set up your Inspiron 16 5645

## About this task

**NOTE:** The images in this document may differ from your computer depending on the configuration you ordered.

## Steps

1. Connect the power adapter and press the power button.



**NOTE:** The battery may go into power-saving mode during shipment to conserve charge on the battery. Ensure that the power adapter is connected to your computer when it is turned on for the first time.

2. Finish the operating system setup.

### For Windows:

Follow the on-screen instructions to complete the setup. When setting up, Dell Technologies recommends that you:





- Connect to a network for Windows updates.

**NOTE:** If connecting to a secured wireless network, enter the password for the wireless network access when prompted.

- If connected to the Internet, sign in with or create a Microsoft account. If not connected to the Internet, create an offline account.
- On the **Support and Protection** screen, enter your contact details.

3. Locate and use Dell apps from the Windows Start menu—Recommended.

**Table 2. Locate Dell apps in Windows**


Resources	Description
	<p><b>My Dell (replaced with Dell Optimizer)</b></p> <p>MyDell (replaced with Dell Optimizer) is a software application that offers you a single streamlined engagement platform including account access, device information, and hardware settings. This software delivers intelligent features that automatically fine-tune your computer for the best possible audio, power, and performance. Get the most out of your Dell device with intelligent, personalized technology from MyDell (replaced with Dell Optimizer). Following are the key features of MyDell (replaced with Dell Optimizer):</p> <ul style="list-style-type: none"> <li>● Application</li> <li>● Audio</li> <li>● Power</li> <li>● Color and Display</li> <li>● Presence detection</li> </ul> <p>For more information about how to use MyDell (replaced with Dell Optimizer), see product guides at <a href="#">Dell Support Site</a>.</p>
	<p><b>Dell Update</b></p> <p>Updates your computer with critical fixes and latest device drivers as they become available. For more information about using Dell Update, see the product guides and third-party license documents at <a href="#">Dell Support Site</a>.</p>
	<p><b>Dell Digital Delivery</b></p> <p>Download software applications, which are purchased but not preinstalled on your computer. For more information about using Dell Digital Delivery, search in the Knowledge Base Resource at <a href="#">Dell Support Site</a>.</p>
	<p><b>SupportAssist</b></p> <p>SupportAssist proactively and predictively identifies hardware and software issues on your computer and automates the engagement process with Dell Technical support. It addresses performance and stabilization issues, prevents security threats, monitors, and detects hardware failures. For more information, see <i>SupportAssist for Home PCs User's Guide</i> at <a href="#">SupportAssist for Home PCs</a>.</p> <p><b>NOTE:</b> In SupportAssist, click the warranty expiry date to renew or upgrade your warranty.</p>

# Specifications of Inspiron 16 5645

## Dimensions and weight

The following table lists the height, width, depth, and weight of your Inspiron 16 5645.

**Table 3. Dimensions and weight**

Description	Values
Height:	
Front height	16.18 mm (0.64 in.)
Rear height	17.37 mm (0.68 in.)
Maximum height	19.05 mm (0.75 in.)
Width	356.78 mm (14.05 in.)
Depth	249.52 mm (9.82 in.)
Weight  <b>NOTE:</b> The weight of your computer depends on the configuration that is ordered and manufacturing variability.	<ul style="list-style-type: none"> <li>• Minimum: 1.87 kg (4.12 lb)</li> <li>• Maximum: 1.93 kg (4.25 lb)</li> </ul>

## Processor

The following table lists the details of the processors that are supported for your Inspiron 16 5645.

**Table 4. Processor**

Description	Option one	Option two
Processor type	AMD Ryzen 5 8540U	AMD Ryzen 7 8840U
Processor wattage	15 W	15 W
Processor core count	6	8
Processor thread count	12	16
Processor speed	3.20 GHz to 4.90 GHz	3.30 GHz to 5.10 GHz
Processor cache	16 MB	16 MB
Integrated graphics	AMD Radeon 740M Graphics	AMD Radeon 780M Graphics

# Chipset

The following table lists the details of the chipset that is supported for your Inspiron 16 5645.

**Table 5. Chipset**

Description	Values
Chipset	Integrated
Processor	AMD Ryzen series
DRAM bus width	64-bit
Flash EPROM	32 MB
PCIe bus	Up to Gen4

# Operating system

Your Inspiron 16 5645 supports the following operating systems:

- Windows 11 Home
- Windows 11 Home National Academic
- Windows 11 Pro
- Windows 11 Pro National Academic

# Memory

The following table lists the memory specifications of your Inspiron 16 5645.

**Table 6. Memory specifications**

Description	Values
Memory slots	Two SODIMM
Memory type	DDR5
Memory speed	5600 MT/s
Maximum memory configuration	32 GB
Minimum memory configuration	8 GB
Memory size per slot	8 GB or 16 GB
Memory configurations supported	<ul style="list-style-type: none"><li>• 8 GB: 1 x 8 GB, DDR5, 5600 MT/s, single-channel</li><li>• 16 GB: 2 x 8 GB, DDR5, 5600 MT/s, dual-channel</li><li>• 24 GB: 1 x 8 GB + 1 x 16 GB, DDR5, 5600 MT/s, dual-channel</li><li>• 32 GB: 2 x 16 GB, DDR5, 5600 MT/s, dual-channel</li></ul>

## External ports

The following table lists the external ports on your Inspiron 16 5645.

**Table 7. External ports**

Description	Values
USB ports	<ul style="list-style-type: none"> <li>Two USB 3.2 Gen 1 (5 Gbps) ports</li> <li>One USB 3.2 Gen 2 (10 Gbps) Type-C with DisplayPort 1.4 and PowerDelivery port</li> </ul>
Audio port	One Universal audio port
Video port/ports	One HDMI 1.4 port
Media-card reader	One SD-card slot
Power-adaptor port	One power-adaptor port
Security-cable slot	One wedge-shaped lock slot

## Internal slots

The following table lists the internal slots of your Inspiron 16 5645.

**Table 8. Internal slots**

Description	Values
M.2	<ul style="list-style-type: none"> <li>One M.2 2230 slot for Wi-Fi and Bluetooth combo card</li> <li>One M.2 2230 slot for solid-state drive</li> </ul> <p><b>NOTE:</b> To learn more about the features of different types of M.2 cards, search in the Knowledge Base Resource at <a href="#">Dell Support Site</a>.</p>


## Wireless module

The following table lists the Wireless Local Area Network (WLAN) modules that are supported on your Inspiron 16 5645.

**Table 9. Wireless module specifications**

Description	Option one	Option two
Model number	Realtek RTL8852BE	Realtek RTL8852CE
Transfer rate	1.20 Gbps	2.40 Gbps
Frequency bands supported	2.4 GHz/5 GHz	2.4 GHz/5 GHz/6 GHz
Wireless standards	<ul style="list-style-type: none"> <li>Wi-Fi 802.11a/b/g</li> <li>Wi-Fi 4 (Wi-Fi 802.11n)</li> <li>Wi-Fi 5 (Wi-Fi 802.11ac)</li> <li>Wi-Fi 6 (Wi-Fi 802.11ax)</li> </ul>	<ul style="list-style-type: none"> <li>Wi-Fi 802.11a/b/g</li> <li>Wi-Fi 4 (Wi-Fi 802.11n)</li> <li>Wi-Fi 5 (Wi-Fi 802.11ac)</li> <li>Wi-Fi 6E (Wi-Fi 802.11ax)</li> </ul>
Encryption	<ul style="list-style-type: none"> <li>64-bit/128-bit WEP</li> <li>AES-CCMP</li> </ul>	<ul style="list-style-type: none"> <li>64-bit/128-bit WEP</li> <li>AES-CCMP</li> </ul>

**Table 9. Wireless module specifications (continued)**

Description	Option one	Option two
	<ul style="list-style-type: none"> <li>TKIP</li> </ul>	<ul style="list-style-type: none"> <li>TKIP</li> </ul>
Bluetooth wireless card	Bluetooth 5.3	Bluetooth 5.3
	 <b>NOTE:</b> The version of the Bluetooth wireless card may vary depending on the operating system that is installed on your computer.	

## Audio

The following table lists the audio specifications of your Inspiron 16 5645.

**Table 10. Audio specifications**

Description	Values	
Audio controller	Realtek ALC3254	
Stereo conversion	Supported	
Internal audio interface	High-definition audio interface	
External audio interface	One Universal audio port	
Number of speakers	2 W per channel	
Internal-speaker amplifier	Supported (Audio codec integrated)	
External volume controls	Keyboard shortcut controls	
Speaker output:		
	Average speaker output	2 W
	Peak speaker output	2.5 W
Subwoofer output	Not supported	
Microphone	Dual-array microphones	

## Storage

This section lists the storage options on your Inspiron 16 5645.

Your Inspiron 16 5645 supports only one M.2 2230 solid-state drive.


**Table 11. Storage specifications**

Storage type	Interface type	Capacity
M.2 2230 PCIe NVMe Class 25 solid-state drive	Gen 4 PCIe NVMe	Up to 1 TB
M.2 2230 PCIe NVMe Class 35 solid-state drive	Gen 4 PCIe NVMe	Up to 1 TB

## Media-card reader

The following table lists the media cards that are supported on your Inspiron 16 5645.


**Table 12. Media-card reader specifications**

Description	Values
Media-card type	One SD-card slot
Media-cards supported	<ul style="list-style-type: none"> <li>Secure Digital (SD)</li> <li>Secure Digital High Capacity (SDHC)</li> <li>Secure Digital Extended Capacity (SDXC)</li> </ul>
<p> <b>NOTE:</b> The maximum capacity that is supported by the media-card reader varies depending on the standard of the media card that is installed on your computer.</p>	

## Keyboard

The following table lists the keyboard specifications of your Inspiron 16 5645.

**Table 13. Keyboard specifications**

Description	Values
Keyboard type	Standard AI hotkey backlit keyboard
Keyboard layout	QWERTY
Number of keys	<p>Midnight Blue chassis:</p> <ul style="list-style-type: none"> <li>English (International), English (US), Arabic, Canada (Bilingual), Chinese (Traditional), Greek, Hebrew, Korean: 99 keys</li> <li>English (UK), German, Nordic (MUI), Slovenian: 100 keys</li> <li>Japanese: 103 keys</li> </ul> <p>Ice Blue chassis:</p> <ul style="list-style-type: none"> <li>English (International), English (US), Greek, Korean, Thai: 99 keys</li> <li>English (UK), Belgian, French (European), German, Italian, Nordic (MUI), Spanish (Castilian), Spanish (Latin America), Swiss/European (MUI), Turkish: 100 keys</li> <li>Japanese: 103 keys</li> </ul>
Keyboard size	<p>X= 18.70 mm key pitch</p> <p>Y= 18.05 mm key pitch</p>
Keyboard shortcuts	<p>Some keys on your keyboard have two symbols on them. These keys can be used to type alternate characters or to perform secondary functions. To type the alternate character, press Shift and the desired key. To perform secondary functions, press Fn and the desired key.</p> <p> <b>NOTE:</b> You can define the primary behavior of the function keys (F1–F12) changing <b>Function Key Behavior</b> in BIOS setup program.</p>

# Keyboard function keys

**i** **NOTE:** Keyboard characters may differ depending on the keyboard language configuration. Keys that are used for shortcuts remain the same across all language configurations.

Some keys on your keyboard have two symbols on them. These keys can be used to type alternate characters or to perform secondary functions. The symbol that is shown on the lower part of the key refers to the character that is typed out when the key is pressed. If you press shift and the key, the symbol that is shown on the upper part of the key is typed out. For example, if you press 2, **2** is typed out; if you press Shift + 2, **@** is typed out.

The keys F1-F12 at the top row of the keyboard are function keys for multimedia control, as indicated by the icon on the key. Press the function key to invoke the task represented by the icon. For example, pressing F1 mutes the audio (see the table below).

However, if the function keys F1-F12 are needed for specific software applications, multimedia functionality can be disabled by pressing Fn + Esc. Later, multimedia control can be invoked by pressing fn and the respective function key. For example, mute audio by pressing fn + F1.

**Table 14. Primary behavior of function keys**

Function key	Primary behavior
F1	Mute/unmute audio
F2	Decrease audio volume
F3	Increase audio volume
F4	Play or pause media file
F5	Turn on or turn off keyboard backlight
F6	Decrease display brightness
F7	Increase display brightness
F8	Switch to an external display
F10	Print screen (screen capture)
F11	Move cursor to the beginning of the line
F12	Move cursor to the end of the line

The **fn** key is also used with selected keys on the keyboard to invoke other secondary functions.

**Table 15. Secondary behavior**

Function key	Secondary behavior
fn + F1	Operating system and application-specific F1 behavior
fn + F2	Operating system and application-specific F2 behavior
fn + F3	Operating system and application-specific F3 behavior
fn + F4	Operating system and application-specific F4 behavior
fn + F5	Operating system and application-specific F5 behavior
fn + F6	Operating system and application-specific F6 behavior
fn + F8	Operating system and application-specific F8 behavior
fn + F9	Operating system and application-specific F9 behavior
fn + F10	Operating system and application-specific F10 behavior
fn + F11	Operating system and application-specific F11 behavior
fn + F12	Operating system and application-specific F12 behavior
fn + B	Pause or Break

**Table 15. Secondary behavior (continued)**

Function key	Secondary behavior
fn + S	Toggle scroll lock
fn + R	System request
fn + Copilot	Open the application menu
fn + Esc	Toggles the function key on and off
fn + PgUp	Scroll up the document or page
fn + PgDn	Scroll down the document or page
fn + left arrow	Home (move to the beginning of the document)
fn + right arrow	End (move to the end of the document)

## Camera

The following table lists the camera specifications of your Inspiron 16 5645.

**Table 16. Camera specifications**

Description	Values
Number of cameras	One
Camera type	RGB FHD camera
Camera location	Front
Camera sensor type	CMOS sensor technology
Camera resolution:	
Still image	2.07 megapixel
Video	1920 x 1080 (FHD at 30 fps)
Diagonal viewing angle:	82.20 degrees

## Touchpad

The following table lists the touchpad specifications of your Inspiron 16 5645.

**Table 17. Touchpad specifications**

Description	Values
Touchpad resolution:	
Horizontal	305
Vertical	305
Touchpad dimensions:	
Horizontal	115 mm (4.52 in.)
Vertical	80 mm (3.15 in.)


**Table 17. Touchpad specifications (continued)**

Description	Values
Touchpad gestures	For more information about touchpad gestures available on Windows, see the Microsoft Knowledge Base article at <a href="#">Microsoft Support Site</a> .

## Power adapter

The following table lists the power adapter specifications of your Inspiron 16 5645.




**Table 18. Power adapter specifications**

Description	Values
Type	65 W
Connector dimensions:	
External diameter	4.50 mm
Internal diameter	2.90 mm
Power-adapter dimensions:	
Height	28 mm (1.10 in.)
Width	47 mm (1.85 in.)
Depth	108 mm (4.25 in.)
Power-adapter weight (maximum)	0.29 kg (0.64 lb)
Input voltage	100 VAC–240 VAC
Input frequency	50 Hz–60 Hz
Input current (maximum)	1.70 A
Output current (continuous)	3.34 A
Rated output voltage	19.50 VDC
Temperature range:	
Operating	0°C to 40°C (32°F to 104°F)
Storage	-40°C to 70°C (-40°F to 158°F)
 <b>CAUTION: Operating and storage temperature ranges may differ among components, so operating or storing the device outside these ranges may impact the performance of specific components.</b>	

# Battery

The following table lists the battery specifications of your Inspiron 16 5645.

**Table 19. Battery specifications**

Description		Option one	Option two
Battery type		4-cell, 54 Wh, Lithium Ion Polymer, ExpressCharge Capable	4-cell, 64 Wh, Lithium Ion Polymer, ExpressCharge Capable
Battery voltage		15 VDC	15.20 VDC
Battery weight (maximum)		0.24 kg (0.53 lb)	0.27 kg (0.60 lb)
Battery dimensions:			
	Height	5.75 mm (0.22 in.)	5.75 mm (0.22 in.)
	Width	271.90 mm (10.66 in.)	271.90 mm (10.66 in.)
	Depth	82 mm (3.22 in.)	82 mm (3.22 in.)
Temperature range:			
	Operating	0°C to 50°C (32°F to 122°F)	0°C to 50°C (32°F to 122°F)
	Storage	-20°C to 60°C (-4°F to 140°F)	-20°C to 60°C (-4°F to 140°F)
Battery operating time		Varies depending on operating conditions and can significantly reduce under certain power-intensive conditions.	Varies depending on operating conditions and can significantly reduce under certain power-intensive conditions.
Battery charging time (approximate)  <b>NOTE:</b> Control the charging time, duration, start and end time, and so on, using the Dell Power Manager application. For more information about Dell Power Manager, search in the Knowledge Base Resource at <a href="#">Dell Support Site</a> .		<ul style="list-style-type: none"> <li>• 3 hr (Standard charge)</li> <li>• 2 hr (Express charge )</li> </ul>	<ul style="list-style-type: none"> <li>• 3 hr (Standard charge)</li> <li>• 2 hr (Express charge )</li> </ul>
Coin-cell battery		N/A	N/A
 <b>CAUTION:</b> Operating and storage temperature ranges may differ among components, so operating or storing the device outside these ranges may impact the performance of specific components.			
 <b>CAUTION:</b> Dell Technologies recommends that you charge the battery regularly for optimal power consumption. If your battery charge is depleted, connect the power adapter, turn on your computer, and then restart your computer to reduce the power consumption.			

# Display

The following table lists the display specifications of your Inspiron 16 5645.

**Table 20. Display specifications**

Description		Option one	Option two	Option three
Display type		16" Full High Definition Plus (FHD+) with ComfortView	16" Full High Definition Plus (FHD+) with ComfortView Plus	16" Full High Definition Plus (FHD+) with ComfortView Plus
Touch options		No	No	Yes
Display-panel technology		Wide Viewing Angle (WVA)	Wide Viewing Angle (WVA)	Wide Viewing Angle (WVA)
Display-panel dimensions (active area):				
	Height	344.68 mm ( 13.57 in.)	344.68 mm ( 13.57 in.)	344.68 mm ( 13.57 in.)
	Width	215.42 mm (8.48 in.)	215.42 mm (8.48 in.)	215.42 mm (8.48 in.)
	Diagonal	406.46 mm (16 in.)	406.46 mm (16 in.)	406.46 mm (16 in.)
Display-panel native resolution		1920 x 1200	1920 x 1200	1920 x 1200
Luminance (typical)		250 nits	300 nits	300 nits
Megapixels		2.30 M	2.30 M	2.30 M
Color gamut		45% NTSC (typical)	100% sRGB (typical)	100% sRGB (typical)
Pixels Per Inch (PPI)		141	141	141
Contrast ratio (typical)		<ul style="list-style-type: none"> <li>● 1000:1 (typical)</li> <li>● 800:1 (minimum)</li> </ul>	<ul style="list-style-type: none"> <li>● 1200:1 (typical)</li> <li>● 1000:1 (minimum)</li> </ul>	<ul style="list-style-type: none"> <li>● 1200:1 (typical)</li> <li>● 1000:1 (minimum)</li> </ul>
Response time (maximum)		35 ms	35 ms	35 ms
Refresh rate		60 Hz	60 Hz	60 Hz
Horizontal view angle		<ul style="list-style-type: none"> <li>● +/- 85 degrees, typical</li> <li>● +/- 80 degrees, minimum</li> </ul>	<ul style="list-style-type: none"> <li>● +/- 85 degrees, typical</li> <li>● +/- 80 degrees, minimum</li> </ul>	<ul style="list-style-type: none"> <li>● +/- 85 degrees, typical</li> <li>● +/- 80 degrees, minimum</li> </ul>
Vertical view angle		<ul style="list-style-type: none"> <li>● +/- 85 degrees, typical</li> <li>● +/- 80 degrees, minimum</li> </ul>	<ul style="list-style-type: none"> <li>● +/- 85 degrees, typical</li> <li>● +/- 80 degrees, minimum</li> </ul>	<ul style="list-style-type: none"> <li>● +/- 85 degrees, typical</li> <li>● +/- 80 degrees, minimum</li> </ul>
Pixel pitch		0.18 mm	0.18 mm	0.18 mm
Power consumption (maximum)		4.20 W	4.40 W	4.73 W
Anti-glare vs glossy finish		Anti-Glare	Anti-Glare	Glossy

## Fingerprint reader (optional)

The following table lists the specifications of the optional fingerprint-reader of your Inspiron 16 5645.

**Table 21. Fingerprint reader specifications**

Description	Values
Fingerprint-reader sensor technology	Capacitive
Fingerprint-reader sensor resolution	500 dpi
Fingerprint-reader sensor pixel size	108 mm x 88 mm

## Sensor

The following table lists the sensor of your Inspiron 16 5645.

**Table 22. Sensor**

Sensor support
Accelerometer

## GPU—Integrated

The following table lists the specifications of the integrated Graphics Processing Unit (GPU) supported by your Inspiron 16 5645.


**Table 23. GPU—Integrated**

Controller	Memory size	Processor
AMD Radeon 740M/780M Graphics	Shared system memory	AMD Ryzen 5 8540U/7 8840U

## External display support

The following table lists the external display support for your Inspiron 16 5645.

**Table 24. External display support**

Graphics card	Supported external displays with laptop display enabled	Supported external displays with laptop display disabled
AMD Radeon 740M/780M Graphics	2	2
 <b>NOTE:</b> For more information about external display support, see the <i>External Display Connection Guide</i> on <a href="#">Dell Support Site</a> .		

# Hardware security

The following table lists the hardware security of your Inspiron 16 5645.

**Table 25. Hardware security**

Hardware security
Wedge-shaped lock
Trusted Platform Module (TPM) 2.0
Windows Hello - Fingerprint Reader (optional)
Camera shutter


# Operating and storage environment

This table lists the operating and storage specifications of your Inspiron 16 5645.

**Airborne contaminant level:** G1 as defined by ISA-S71.04-1985

**Table 26. Computer environment**

Description	Operating	Storage
Temperature range	0 °C–35°C (32 °F–95°F)	-40°C to 65°C (-40°F to 149°F)
Relative humidity (maximum)	10% to 90% (non-condensing)	5% to 95% (non-condensing)
Vibration (maximum)*	0.66 GRMS	1.30 GRMS
Shock (maximum)	110 G†	160 G†
Altitude range	-15.2 m to 3048 m (-49.87 ft to 10,000 ft)	-15.2 m to 10,668 m (-49.87 ft to 35,000 ft)

 **CAUTION: Operating and storage temperature ranges may differ among components, so operating or storing the device outside these ranges may impact the performance of specific components.**

\* Measured using a random vibration spectrum that simulates the user environment.

† Measured using a 2 ms half-sine pulse.

# Dell support policy

For information about Dell support policy, search in the Knowledge Base Resource at [Dell Support Site](#).

# ComfortView

 **WARNING: Prolonged exposure to blue light from the display may lead to long-term effects such as eye strain, eye fatigue, or damage to the eyes.**

Blue light is a color in the light spectrum which has a short wavelength and high energy. Chronic exposure to blue light, particularly from digital sources may disrupt sleep patterns and cause long-term effects such as eye strain, eye fatigue, or damage to the eyes.

ComfortView mode can be enabled and configured using the Dell CinemaColor application.


ComfortView mode complies with TÜV Rheinland's requirement for low blue light displays.

Low blue light: Dell ComfortView software technology reduces harmful blue light emissions to make extended screen time easy on your eyes.

To reduce the risk of eye strain, it is also recommended that you:

- Position the display at a comfortable viewing distance between 20 and 28 inches (50 cm and 70 cm) from your eyes.
- Blink frequently to moisten your eyes, wet your eyes with water, or apply suitable eye drops.
- Look away from your display, and gaze at a distant object at 20 ft (609.60 cm) away for at least 20 seconds during each break.
- Take an extended break for 20 minutes every two hours.

## ComfortView Plus

 **WARNING: Prolonged exposure to blue light from the display may lead to long-term effects such as eye strain, eye fatigue, or damage to the eyes.**

Blue light is a color in the light spectrum which has a short wavelength and high energy. Chronic exposure to blue light, particularly from digital sources may disrupt sleep patterns and cause long-term effects such as eye strain, eye fatigue, or damage to the eyes.

The display on this computer is designed to minimize blue light and complies with TÜV Rheinland's requirement for low blue light displays.

Low blue light mode is enabled at the factory, so no further configuration is necessary.











To reduce the risk of eye strain, it is also recommended that you:

- Position the display at a comfortable viewing distance between 20 and 28 inches (50 cm and 70 cm) from your eyes.
- Blink frequently to moisten your eyes, wet your eyes with water, or apply suitable eye drops.
- Look away from your display, and gaze at a distant object at 20 ft (609.60 cm) away for at least 20 seconds during each break.
- Take an extended break for 20 minutes every two hours.

# Working inside your computer


## Safety instructions

Use the following safety guidelines to protect your computer from potential damage and to ensure your personal safety. Unless otherwise noted, each procedure in this document assumes that you have read the safety information that shipped with your computer.



-  **WARNING:** Before working inside your computer, read the safety information that is shipped with your computer. For more safety best practices, see [Dell Regulatory Compliance Home Page](#).
-  **WARNING:** Disconnect your computer from all power sources before opening the computer cover or panels. After you finish working inside the computer, replace all covers, panels, and screws before connecting your computer to an electrical outlet.
-  **CAUTION:** To avoid damaging the computer, ensure that the work surface is flat, dry, and clean.
-  **CAUTION:** To avoid damaging the components and cards, handle them by their edges, and avoid touching the pins and the contacts.
-  **CAUTION:** You should only perform troubleshooting and repairs as authorized or directed by the Dell technical assistance team. Damage due to servicing that is not authorized by Dell is not covered by your warranty. See the safety instructions that is shipped with the product or at [Dell Regulatory Compliance Home Page](#).
-  **CAUTION:** Before touching anything inside your computer, ground yourself by touching an unpainted metal surface, such as the metal at the back of the computer. While you work, periodically touch an unpainted metal surface to dissipate static electricity which could harm internal components.
-  **CAUTION:** When you disconnect a cable, pull it by its connector or its pull tab, not the cable itself. Some cables have connectors with locking tabs or thumbscrews that you must disengage before disconnecting the cable. When disconnecting cables, keep them evenly aligned to avoid bending the connector pins. When connecting cables, ensure that the ports and the connectors are correctly oriented and aligned.
-  **CAUTION:** Press and eject any installed card from the media-card reader.
-  **CAUTION:** Exercise caution when handling rechargeable Li-ion batteries in laptops. Swollen batteries should not be used and should be replaced and disposed properly.
-  **NOTE:** The color of your computer and certain components may differ from what is shown in this document.

## Before working inside your computer

### About this task

-  **NOTE:** The images in this document may differ from your computer depending on the configuration you ordered.

### Steps

1. Save and close all open files and exit all open applications.
2. Shut down your computer. For Windows operating system, click **Start** >  **Power** > **Shut down**.
  -  **NOTE:** If you are using a different operating system, see the documentation of your operating system for shut-down instructions.

3. Disconnect your computer and all attached devices from their electrical outlets.
4. Disconnect all attached network devices and peripherals, such as keyboard, mouse, and monitor from your computer.

 **CAUTION: To disconnect a network cable, first unplug the cable from your computer and then unplug the cable from the network device.**

5. Remove any media card and optical disc from your computer, if applicable.

## Safety precautions

The safety precautions chapter details the primary steps to be taken before performing any disassembly instructions.

Observe the following safety precautions before you perform any installation or break-fix procedures involving disassembly or reassembly:

- Turn off the computer and all attached peripherals.
- Disconnect the computer and all attached peripherals from AC power.
- Disconnect all network cables, telephone, and telecommunications lines from the computer.
- Use an ESD field service kit when working inside any notebook to avoid electrostatic discharge (ESD) damage.
- After removing any computer component, carefully place the removed component on an anti-static mat.
- Wear shoes with non-conductive rubber soles to reduce the chance of getting electrocuted.
- Unplugging, pressing, and holding the power button for 15 seconds should discharge residual power in the system board.

## Standby power

Dell products with standby power must be unplugged before you open the case. Systems that incorporate standby power are powered while turned off. The internal power enables the computer to be remotely turned on (Wake-on-LAN) and suspended into a sleep mode and has other advanced power management features.

## Bonding

Bonding is a method for connecting two or more grounding conductors to the same electrical potential. This is done by using a field service electrostatic discharge (ESD) kit. When connecting a bonding wire, ensure that it is connected to bare metal and never to a painted or nonmetal surface. The wrist strap should be secure and in full contact with your skin, and ensure that you remove all jewelry such as watches, bracelets, or rings prior to bonding yourself and the equipment.

## Electrostatic discharge—ESD protection

ESD is a major concern when you handle electronic components, especially sensitive components such as expansion cards, processors, memory modules, and system boards. Slight charges can damage circuits in ways that may not be obvious, such as intermittent problems or a shortened product life span. As the industry pushes for lower power requirements and increased density, ESD protection is an increasing concern.

Due to the increased density of semiconductors used in recent Dell products, the sensitivity to static damage is now higher than in previous Dell products. For this reason, some previously approved methods of handling parts are no longer applicable.

Two recognized types of ESD damage are catastrophic and intermittent failures.

- **Catastrophic** – Catastrophic failures represent approximately 20 percent of ESD-related failures. The damage causes an immediate and complete loss of device functionality. An example of catastrophic failure is a memory DIMM that has received a static shock and immediately generates a "No POST/No Video" symptom with a beep code that is emitted for missing or nonfunctional memory.
- **Intermittent** – Intermittent failures represent approximately 80 percent of ESD-related failures. The high rate of intermittent failures means that most of the time when damage occurs, it is not immediately recognizable. The DIMM receives a static shock, but the tracing is merely weakened and does not immediately produce outward symptoms that are related to the damage. The weakened trace may take weeks or months to melt, and in the meantime may cause degradation of memory integrity, intermittent memory errors, and so on.

The more difficult type of damage to recognize and troubleshoot is the intermittent (also called latent or "walking wounded") failure.

Perform the following steps to prevent ESD damage:

- Use a wired ESD wrist strap that is properly grounded. Wireless anti-static straps do not provide adequate protection. Touching the chassis before handling parts does not ensure adequate ESD protection on parts with increased sensitivity to ESD damage.
- Handle all static-sensitive components in a static-safe area. If possible, use anti-static floor pads and workbench pads.
- When unpacking a static-sensitive component from its shipping carton, do not remove the component from the anti-static packing material until you are ready to install the component. Before unwrapping the anti-static packaging, ensure that you discharge static electricity from your body.
- Before transporting a static-sensitive component, place it in an anti-static container or packaging.

## ESD Field Service kit

The unmonitored Field Service kit is the most commonly used service kit. Each Field Service kit includes three main components: anti-static mat, wrist strap, and bonding wire.

### Components of an ESD field service kit

The components of an ESD field service kit are:

- **Anti-Static Mat** – The anti-static mat is dissipative and parts can be placed on it during service procedures. When using an anti-static mat, your wrist strap should be snug and the bonding wire should be connected to the mat and to any bare metal on the computer being worked on. Once deployed properly, service parts can be removed from the ESD bag and placed directly on the mat. ESD-sensitive items are safe in your hand, on the ESD mat, in the computer, or inside an ESD bag.
- **Wrist Strap and Bonding Wire** – The wrist strap and bonding wire can be either directly connected between your wrist and bare metal on the hardware if the ESD mat is not required, or connected to the anti-static mat to protect hardware that is temporarily placed on the mat. The physical connection of the wrist strap and bonding wire between your skin, the ESD mat, and the hardware is known as bonding. Use only Field Service kits with a wrist strap, mat, and bonding wire. Never use wireless wrist straps. Always be aware that the internal wires of a wrist strap are prone to damage from normal wear and tear, and must be checked regularly with a wrist strap tester in order to avoid accidental ESD hardware damage. It is recommended to test the wrist strap and bonding wire at least once per week.
- **ESD Wrist Strap Tester** – The wires inside an ESD strap are prone to damage over time. When using an unmonitored kit, it is a best practice to regularly test the strap prior to each service call, and at a minimum, test once per week. A wrist strap tester is the best method for doing this test. If you do not have your own wrist strap tester, check with your regional office to find out if they have one. To perform the test, plug the bonding-wire of wrist-strap into the tester while it is strapped to your wrist and push the button to test. A green LED is lit if the test is successful; a red LED is lit and an alarm sounds if the test fails.
- **Insulator Elements** – It is critical to keep ESD sensitive devices, such as plastic heat sink casings, away from internal parts that are insulators and often highly charged.
- **Working Environment** – Before deploying the ESD Field Service kit, assess the situation at the customer location. For example, deploying the kit for a server environment is different than for a desktop or laptop environment. Servers are typically installed in a rack within a data center; desktops or laptops are typically placed on office desks or cubicles. Always look for a large open flat work area that is free of clutter and large enough to deploy the ESD kit with additional space to accommodate the type of computer that is being repaired. The workspace should also be free of insulators that can cause an ESD event. On the work area, insulators such as Styrofoam and other plastics should always be moved at least 12 inches or 30 centimeters away from sensitive parts before physically handling any hardware components.
- **ESD Packaging** – All ESD-sensitive devices must be shipped and received in static-safe packaging. Metal, static-shielded bags are preferred. However, you should always return the damaged part using the same ESD bag and packaging that the new part arrived in. The ESD bag should be folded over and taped shut and all the same foam packing material should be used in the original box that the new part arrived in. ESD-sensitive devices should be removed from packaging only at an ESD-protected work surface, and parts should never be placed on top of the ESD bag because only the inside of the bag is shielded. Always place parts in your hand, on the ESD mat, in the computer, or inside an anti-static bag.
- **Transporting Sensitive Components** – When transporting ESD sensitive components such as replacement parts or parts to be returned to Dell, it is critical to place these parts in anti-static bags for safe transport.

### ESD protection summary


It is recommended to always use the traditional wired ESD grounding wrist strap and protective anti-static mat when servicing Dell products. In addition, it is critical to keep sensitive parts separate from all insulator parts while performing service and use anti-static bags for transporting sensitive components.

## Transporting sensitive components

When transporting ESD sensitive components such as replacement parts or parts to be returned to Dell, it is critical to place these parts in anti-static bags for safe transport.

## After working inside your computer


### About this task

 **CAUTION:** Leaving stray or loose screws inside your computer may severely damage your computer.

### Steps

1. Replace all screws and ensure that no stray screws remain inside your computer.
2. Connect any external devices, peripherals, or cables you removed before working on your computer.
3. Replace any media cards, discs, or any other parts that you removed before working on your computer.
4. Connect your computer and all attached devices to their electrical outlets.
5. Turn on your computer.

## BitLocker

 **CAUTION:** If BitLocker is not suspended before updating the BIOS, the next time you reboot the system it will not recognize the BitLocker key. You will then be prompted to enter the recovery key to progress, and the system will ask for the recovery key on each reboot. If the recovery key is not known, this can result in data loss or an unnecessary operating system reinstall. For more information about this subject, see Knowledge Article: [updating the BIOS on Dell systems with BitLocker enabled](#).

The installation of the following components triggers BitLocker:


- Hard disk drive or solid-state drive
- System board


## Recommended tools


The procedures in this document may require the following tools:

- Phillips screwdriver #0
- Plastic scribe

## Screw list

 **NOTE:** When removing screws from a component, it is recommended to note the screw type, and the quantity of screws, and then place them in a screw storage box. This is to ensure that the correct number of screws and correct screw type is restored when the component is replaced.

















 **NOTE:** Some computers have magnetic surfaces. Ensure that the screws are not left attached to such surfaces when replacing a component.

 **NOTE:** Screw color may vary with the configuration ordered.

**Table 27. Screw list**

Component	Screw type	Quantity	Screw image
CRU			

**Table 27. Screw list (continued)**

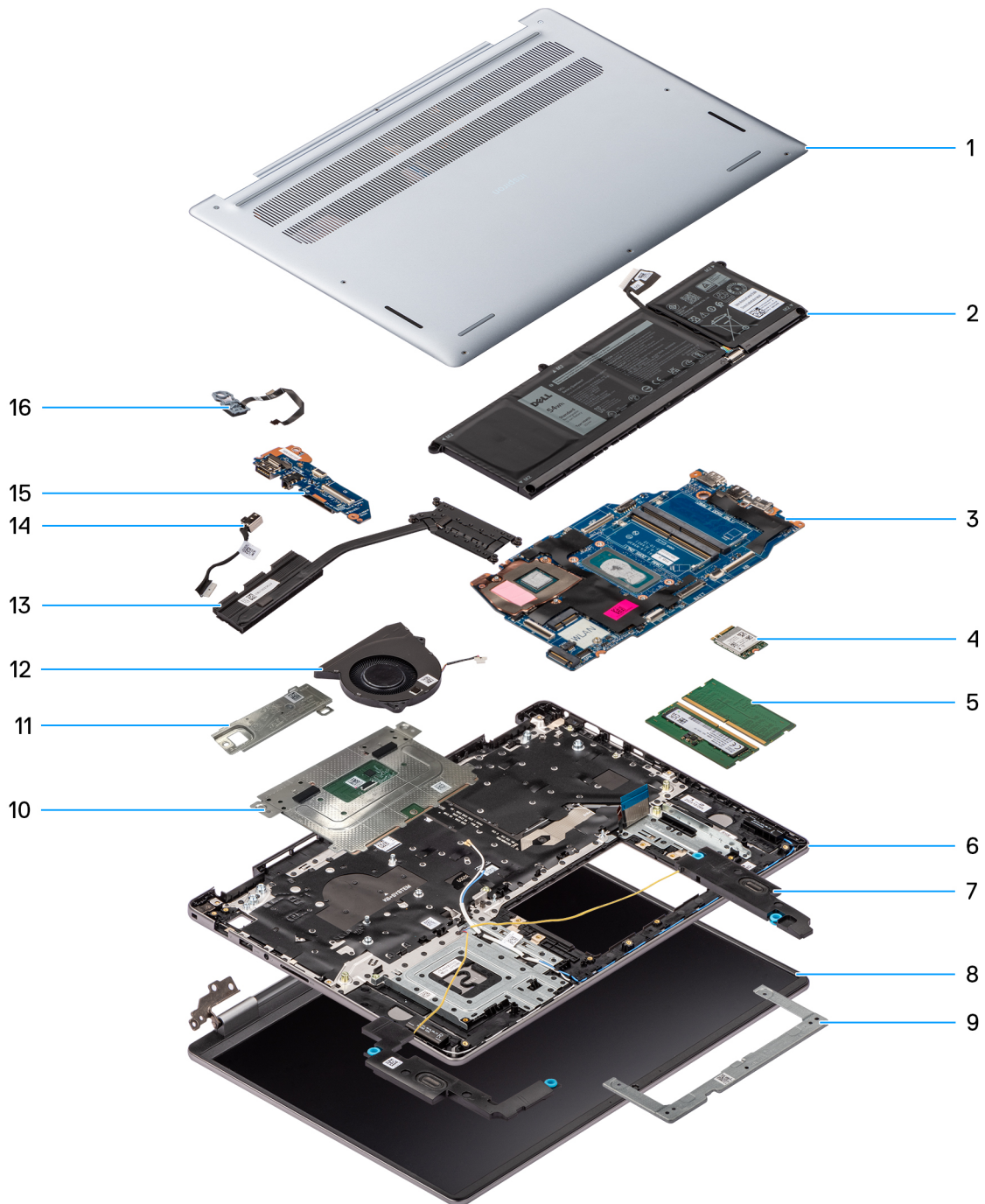
Component	Screw type	Quantity	Screw image
Base cover	Captive screw	2	
	M2x5.5	6	
Solid-state drive mounting bracket	M2x3.5	3	
Solid-state drive	M1.6x1.8	1	
Wireless card	M2x3.5	1	
Fan	M2x5.5	2	
<b>FRU</b>			
Battery	M2x3.5	5	
Heat sink	Captive screws	4	
Touchpad assembly	M2x2.3	7	
Hinges	M2.5x5	5 <i>i</i> <b>NOTE:</b> Right hinge - 2 screws Left hinge - 3 screws	
I/O board	M2x3.5	3	
Power button	M2x2.3	1	
Power button with fingerprint reader (optional)	M2x2.3	1	
System board	M2x3.5	4	
	M1.6x1.8	1	
USB Type-C bracket <i>i</i> <b>NOTE:</b> A USB Type-C bracket is secured to the system board with a single screw (M2x3.5). The bracket is bundled with the system	M2x3.5	1	

**Table 27. Screw list (continued)**

Component	Screw type	Quantity	Screw image
board as a service part and MUST NOT be removed from the system board.			


## Major components of Inspiron 16 5645

The following image shows the major components of Inspiron 16 5645.



**Figure 7. Major components of Inspiron 16 5645**


1. Base cover
2. Battery
3. System board
4. Wireless card
5. Memory modules
6. Palm-rest and keyboard assembly
7. Speakers
8. Display assembly
9. Touchpad bracket
10. Touchpad assembly
11. M.2 2230 solid-state drive with thermal plate
12. Fan
13. Heat sink
14. Power-adaptor port
15. I/O board
16. Power button with optional fingerprint reader

 **NOTE:** Dell provides a list of components and their part numbers for the original computer configuration purchased. These parts are available according to warranty coverage purchased by the customer. Contact your Dell sales representative for purchase options.

# Removing and installing Customer Replaceable Units (CRUs)

The replaceable components in this chapter are Customer Replaceable Units (CRUs).

 **CAUTION:** Customers can replace only the Customer Replaceable Units (CRUs) following the safety precautions and replacement procedures.

 **NOTE:** The images in this document may differ from your computer depending on the configuration you ordered.

## Base cover

### Removing the base cover

#### Prerequisites

1. Follow the procedure in [Before working inside your computer](#).

#### About this task

The following images indicate the location of the base cover and provide a visual representation of the removal procedure.

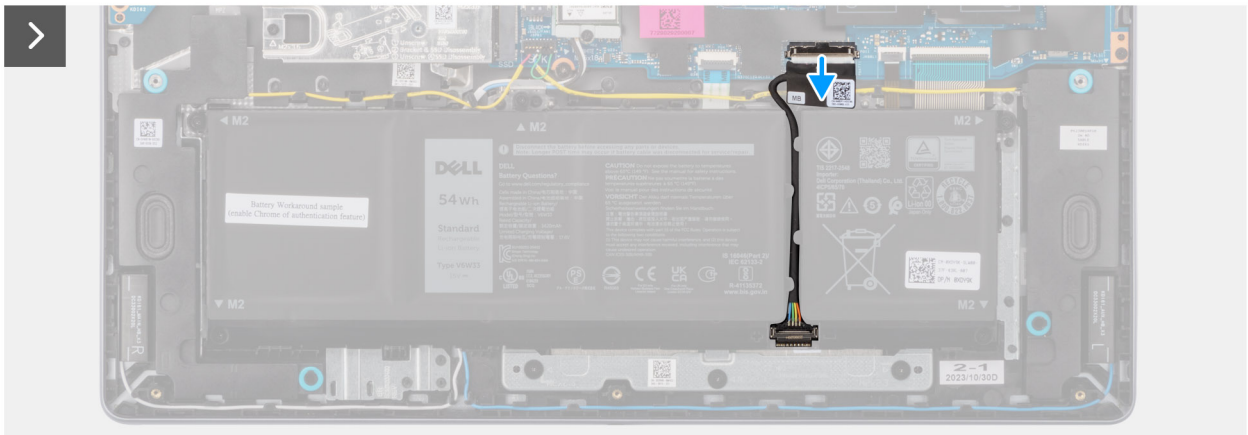
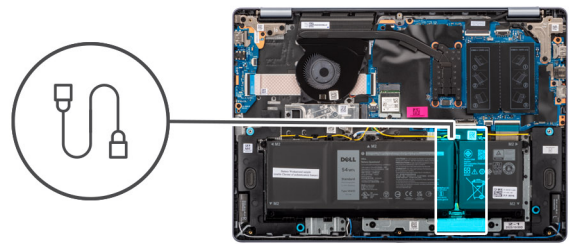
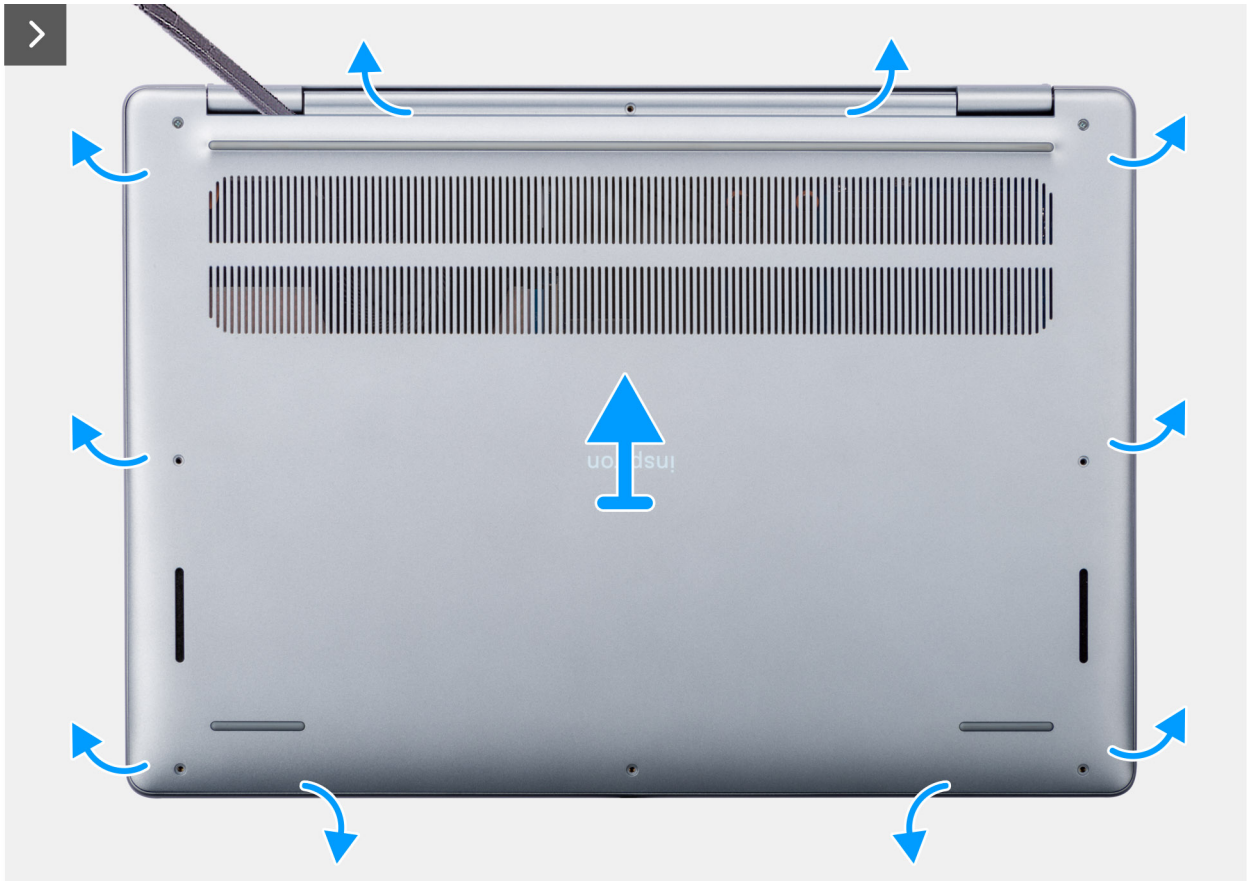


2x



6x  
M2x5.5







**Figure 8. Removing the base cover**

**Steps**

1. Remove the six screws (M2x5.5) and loosen the two captive screws that secure the base cover to the palm-rest and keyboard assembly.
2. Using a plastic scribe, pry open the base cover starting from the recesses, which are located in the U-shaped indents at the top edge of the base cover, near the hinges.
3. Pry open the top side of the base cover and continue working on the left and right sides to open the base cover.
4. Lift and remove the base cover off the palm-rest and keyboard assembly.
5. Disconnect the battery cable from its connector (BATT) on the system board.
6. Press and hold the power button for five seconds to ground the computer and drain the flea power.

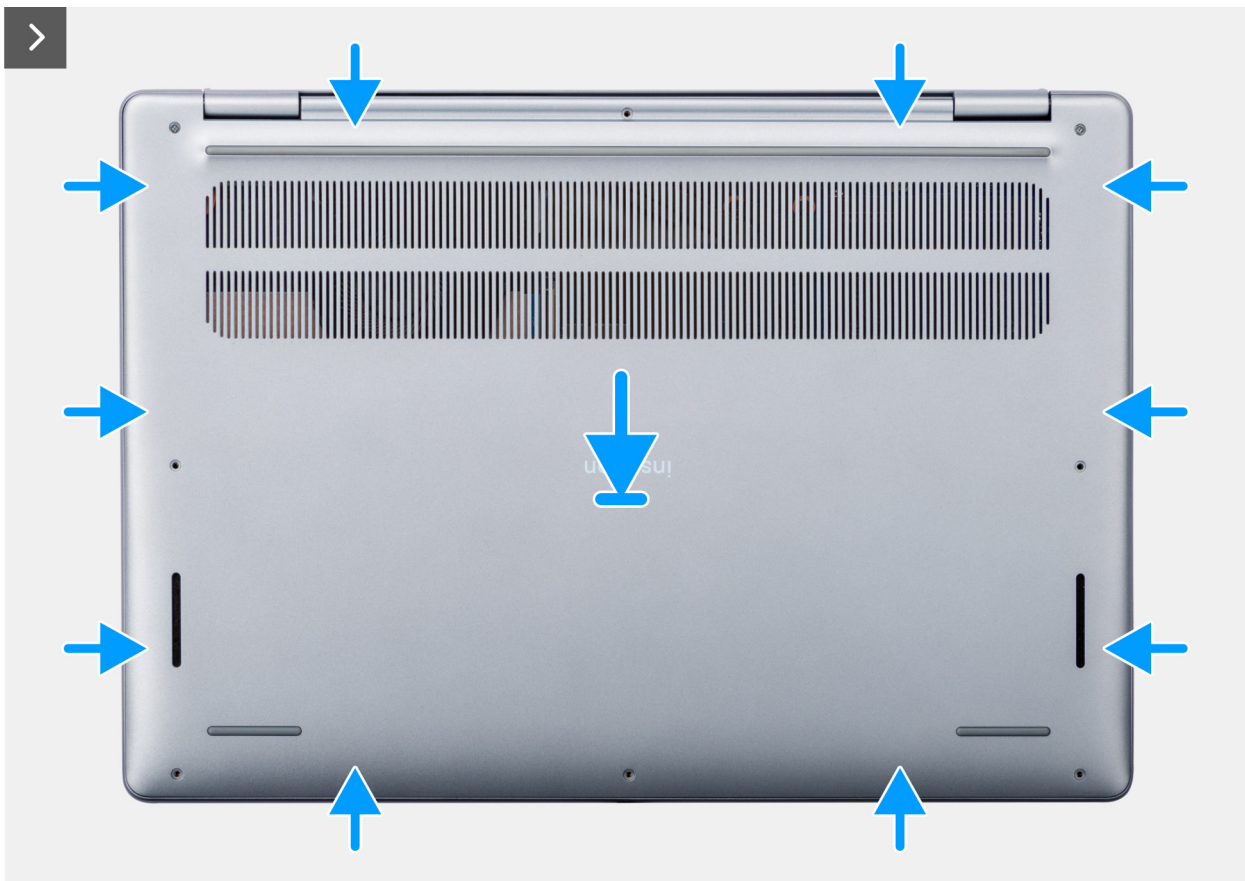
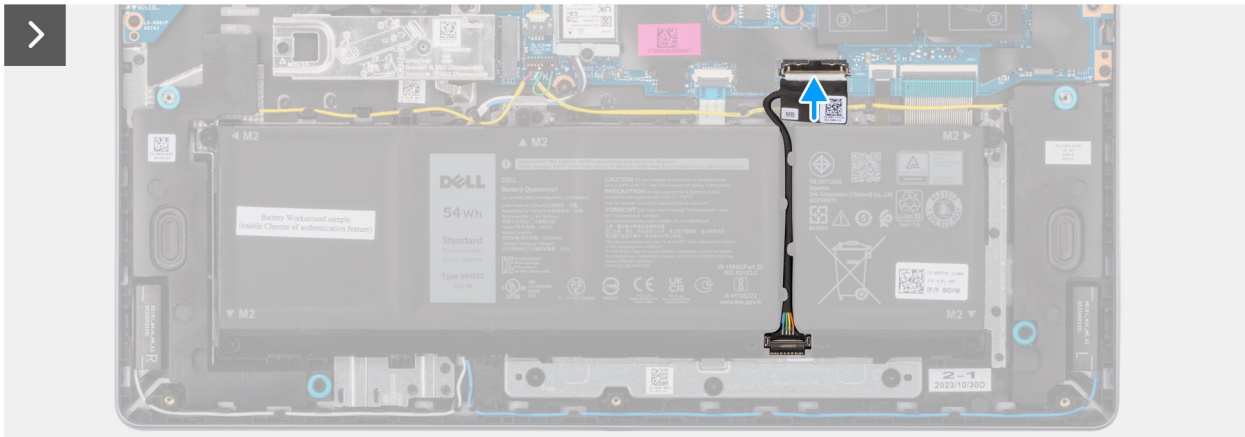
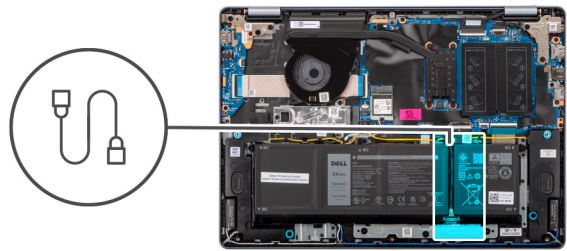
## Installing the base cover

**Prerequisites**

If you are replacing a component, remove the existing component before performing the installation procedure.

**About this task**

The following images indicate the location of the base cover and provide a visual representation of the installation procedure.





**Figure 9. Installing the base cover**

#### Steps

1. Connect the battery cable to its connector (BATT) on the system board.
2. Place the base cover on top of the palm-rest and keyboard assembly.
3. Align the screw holes on the base cover with the screw holes on the palm-rest and keyboard assembly, and snap the base cover latches into place.
4. Tighten the two captive screws and replace the six screws (M2x5.5) that secure the base cover to the palm-rest and keyboard assembly.

#### Next steps

1. Follow the procedure in [After working inside your computer](#).

# Memory module


## Removing the memory module

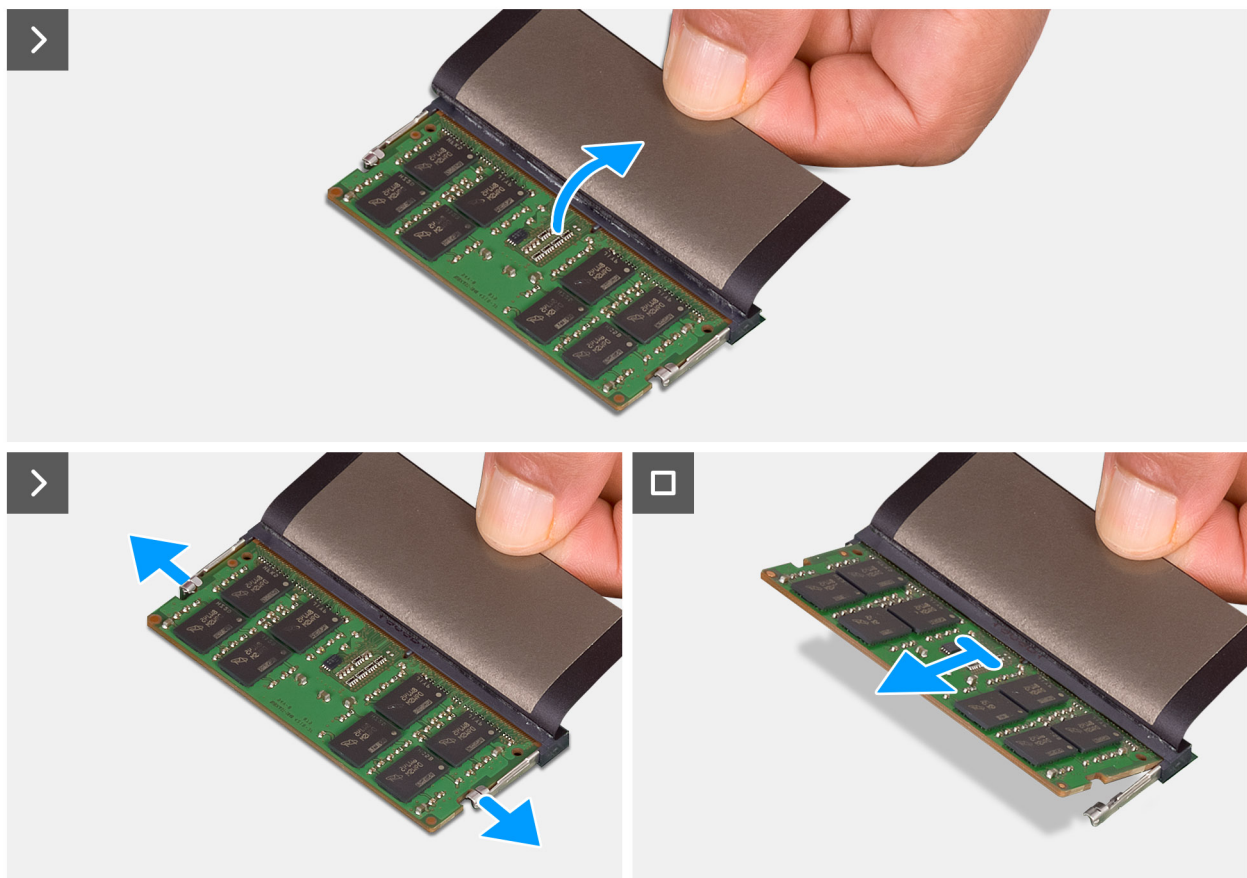
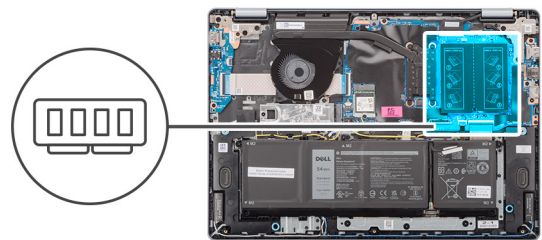
### Prerequisites

1. Follow the procedure in [Before working inside your computer](#).
2. Remove the [base cover](#).

### About this task

The following images indicate the location of the memory module and provide a visual representation of the removal procedure.

 **NOTE:** Inspiron 16 5645 supports a dual-channel RAM memory configuration.



**Figure 10. Removing the memory module**

### Steps

1. Lift the Mylar to access the memory module.
2. Use your fingertips to pull the securing clips from both sides of the memory module until the memory module pops up.

- Slide the memory module at an angle and remove it from the memory-module slot (DIMM A DDR5 ONLY or DIMM B DDR5 ONLY) on the system board.

**CAUTION:** To prevent damage to the memory module, hold the memory module by the edges. Do not touch the components or metallic contacts on the memory module as electrostatic discharge (ESD) can inflict severe damage on the components. To read more about ESD protection, see [ESD protection](#).

## Installing the memory module

### Prerequisites

If you are replacing a component, remove the existing component before performing the installation procedure.

### About this task

The following images indicate the location of the memory module and provide a visual representation of the installation procedure.

**NOTE:** Inspiron 16 5645 supports a dual-channel RAM memory configuration.

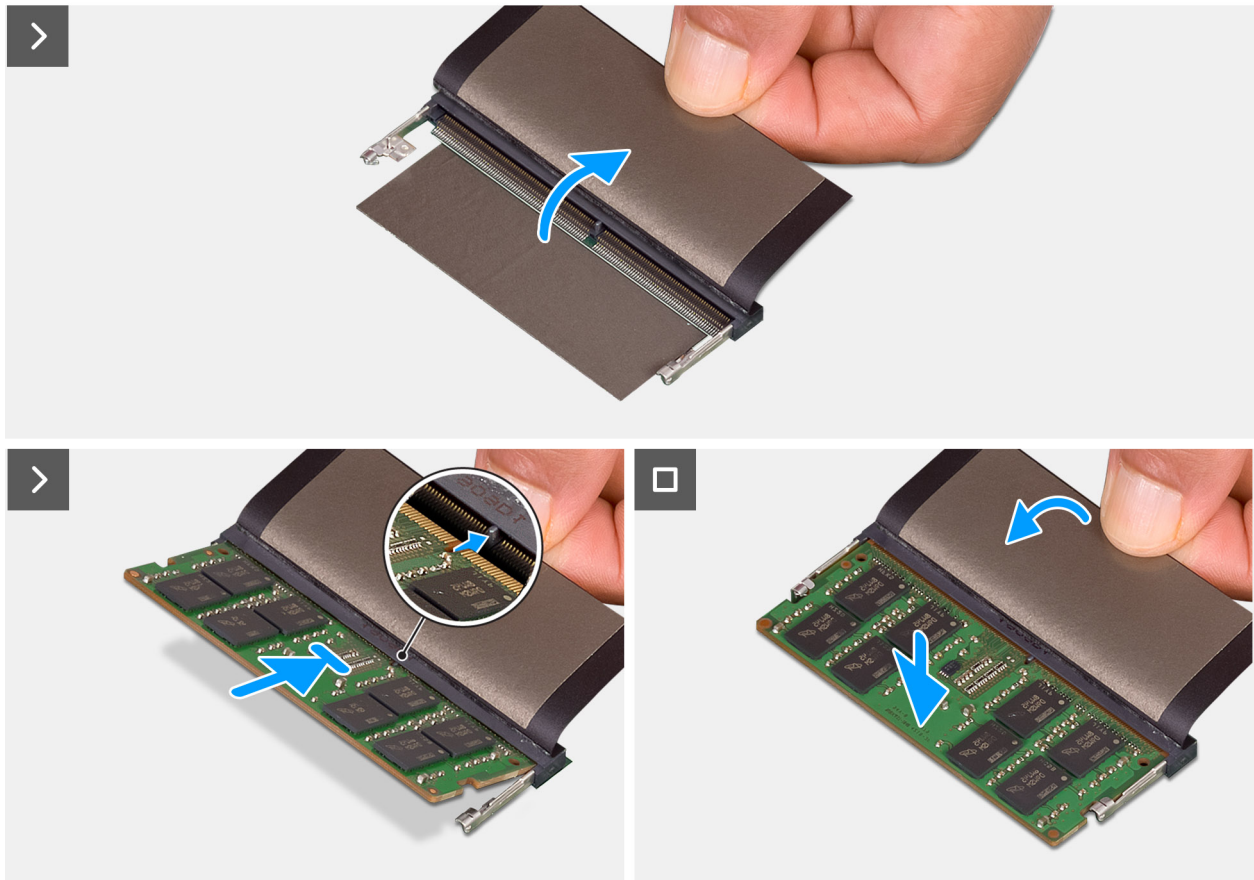
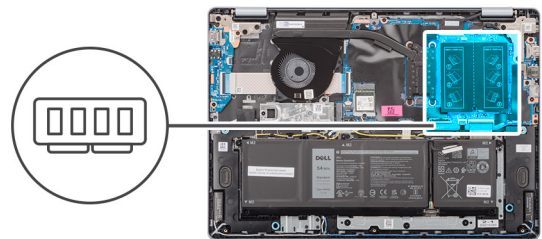


Figure 11. Installing the memory module

## Steps

1. Lift the Mylar to access the memory-module slot.
2. Align the notch on the memory module with the tab on the memory-module slot (DIMM A DDR5 ONLY or DIMM B DDR5 ONLY) on the system board.
3. Slide the memory module firmly into the memory-module slot at an angle.
4. Press down on the memory module to snap it into place on the system board. Ensure that the memory-module retention clips have locked the memory module into place.

**CAUTION:** To prevent damage to the memory module, hold the memory module by the edges. Do not touch the components or metallic contacts on the memory module as electrostatic discharge (ESD) can inflict severe damage on the components. To read more about ESD protection, see [ESD protection](#).

**NOTE:** If you do not hear the click, remove the memory module and reinstall it.

## Next steps

1. Install the [base cover](#).
2. Follow the procedure in [After working inside your computer](#).

# M.2 solid state drive

## Removing the solid-state drive

### Prerequisites

1. Follow the procedure in [Before working inside your computer](#).
2. Remove the [base cover](#).

### About this task

The following images indicate the location of the solid-state drive and provide a visual representation of the removal procedure.

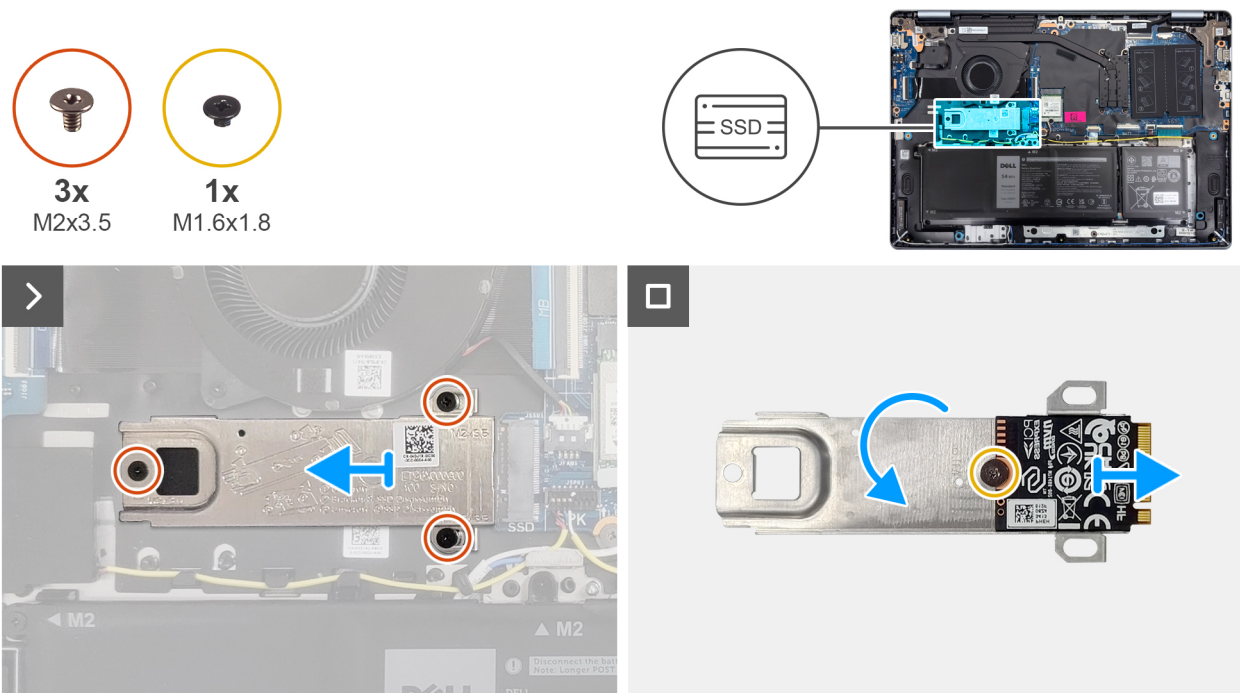


Figure 12. Removing the solid-state drive

## Steps

1. Remove the three screws (M2x3.5) that secure the solid-state drive assembly to the system board.
2. Slide and lift the solid-state drive assembly from the M.2 card slot (SSD) on the system board.
3. Flip over the solid-state drive assembly and remove the screw (M1.6x1.8) that secures the solid-state drive to the thermal plate.
4. Lift the solid-state drive off the thermal plate.

## Installing the solid-state drive

### Prerequisites

If you are replacing a component, remove the existing component before performing the installation procedure.

### About this task

The following images indicate the location of the solid-state drive and provide a visual representation of the installation procedure.

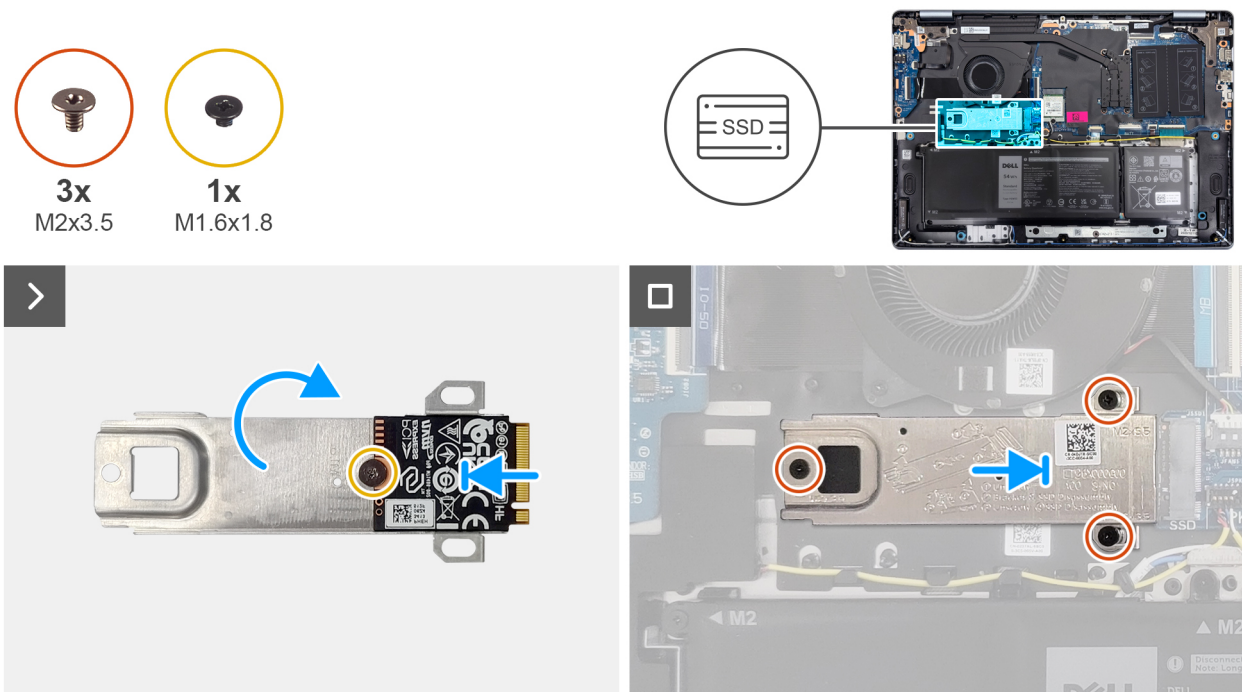


Figure 13. Installing the solid-state drive

## Steps

1. Align and place the solid-state drive on the thermal plate.
2. Replace the screw (M1.6x1.8) that secures the solid-state drive to the thermal plate.
3. Flip over the M.2 2230 solid-state drive assembly.
4. Align the notch on the solid-state drive with the tab on the M.2 card slot (SSD) on the system board.
5. Slide the solid-state drive in the M.2 card slot (SSD) on the system board.
6. Align the screw holes on the thermal plate with the screw holes on the system board.
7. Replace the three screws (M2x3.5) that secure the solid-state drive assembly to the system board.

## Next steps

1. Install the [base cover](#).
2. Follow the procedure in [After working inside your computer](#).

# Wireless card

## Removing the wireless card

### Prerequisites

1. Follow the procedure in [Before working inside your computer](#).
2. Remove the [base cover](#).

### About this task

The following images indicate the location of the wireless card and provide a visual representation of the removal procedure.

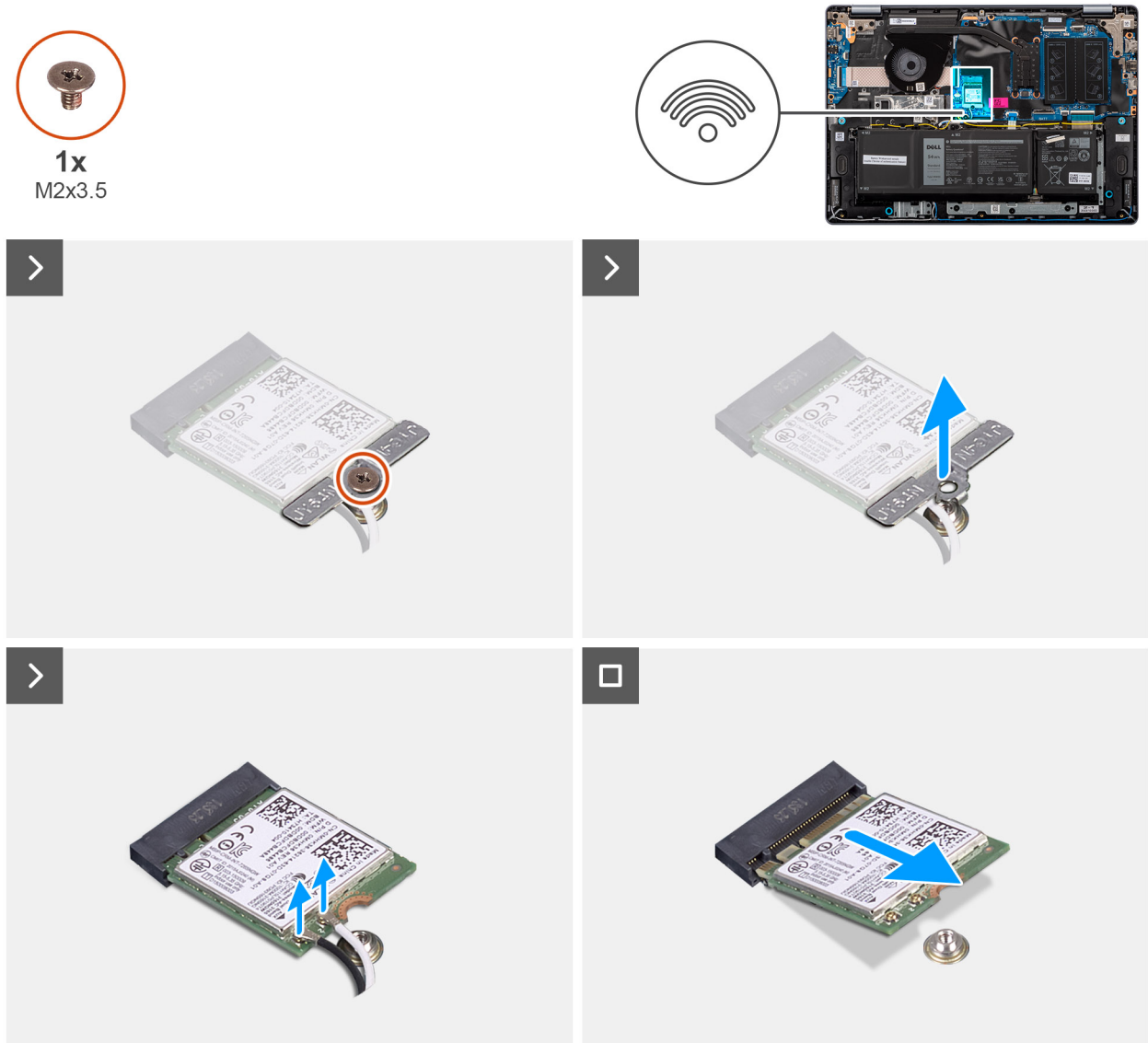


Figure 14. Removing the wireless card

### Steps

1. Remove the screw (M2x3.5) that secures the wireless-card bracket to the system board.
2. Lift the wireless-card bracket off the wireless card.
3. Disconnect the wireless-antenna cables from the connectors on the wireless card.
4. Slide and remove the wireless card from the wireless-card slot (WLAN) on the system board.

# Installing the wireless card

## Prerequisites

If you are replacing a component, remove the existing component before performing the installation procedure.

## About this task

The following images indicate the location of the wireless card and provide a visual representation of the installation procedure.

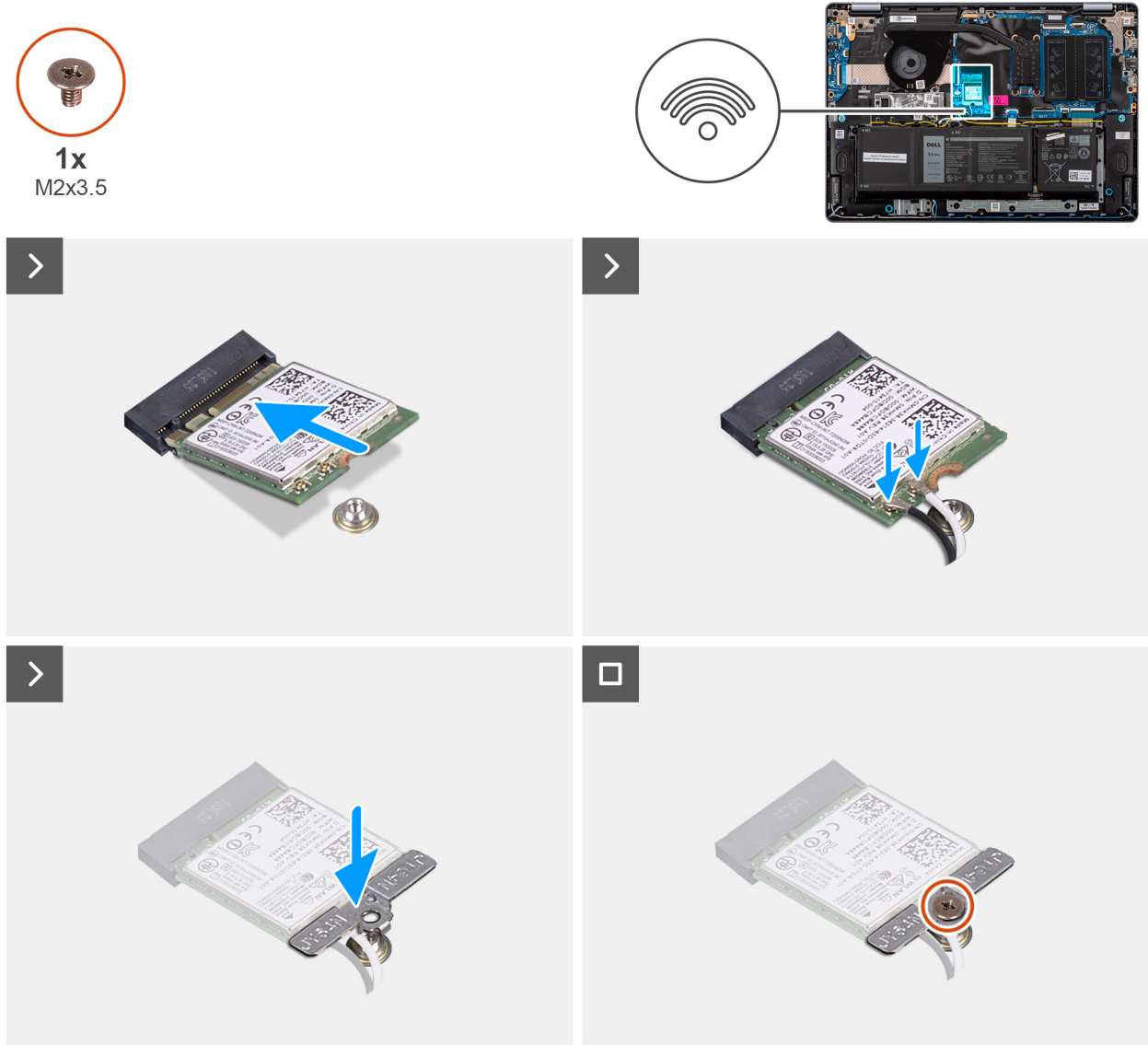


Figure 15. Installing the wireless card

## Steps

1. Connect the wireless-antenna cables to the wireless card.

The following table provides the antenna-cable color scheme for the wireless card that is supported by your computer.

Table 28. Antenna-cable color scheme

Connector on the wireless card	Antenna-cable color	Silkscreen marking	
Main	White	MAIN	△ (white triangle)

**Table 28. Antenna-cable color scheme (continued)**

Connector on the wireless card	Antenna-cable color	Silkscreen marking	
Auxiliary	Black	AUX	▲ (black triangle)

2. At an angle, slide the wireless card into the wireless-card slot (WLAN) on the system board.
3. Place the wireless-card bracket on the wireless card.
4. Align the screw hole on the wireless-card bracket with the screw hole on the system board.
5. Replace the screw (M2x3.5) that secure the wireless-card bracket and the wireless card to the system board.

**Next steps**

1. Install the [base cover](#).
2. Follow the procedure in [After working inside your computer](#).

## Speakers

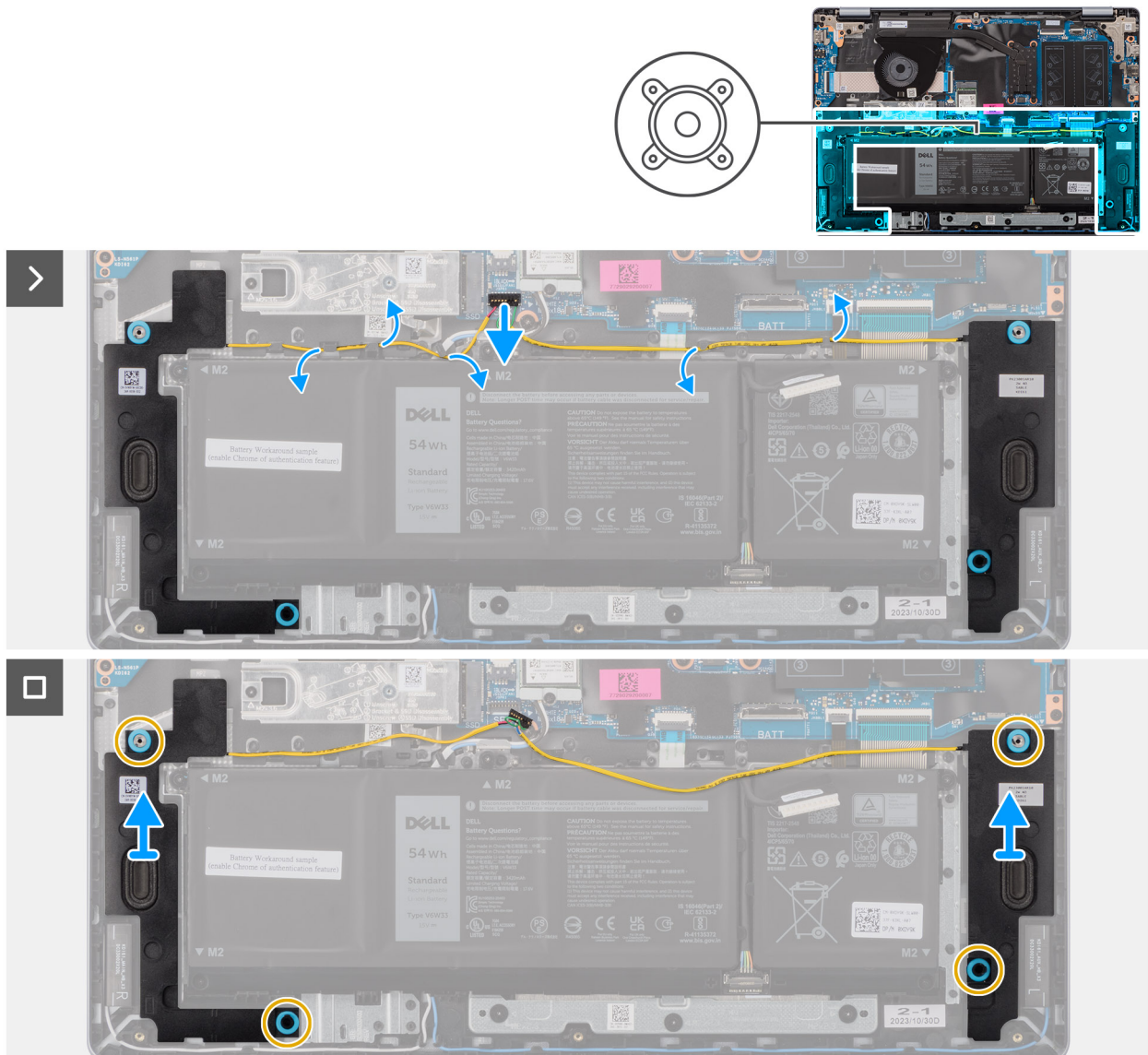
### Removing the speakers

**Prerequisites**

1. Follow the procedure in [Before working inside your computer](#).
2. Remove the [base cover](#).

**About this task**

The following image indicates the location of the speakers and provides a visual representation of the removal procedure.

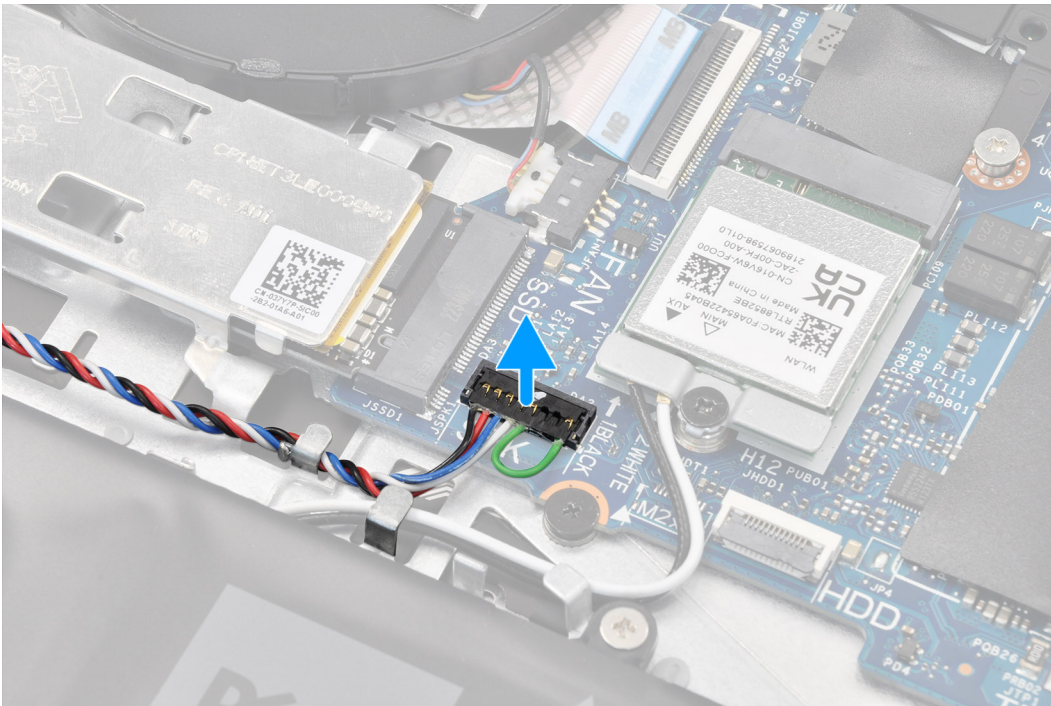


**Figure 16. Removing the speakers**

**Steps**

1. Disconnect the speaker cable from its connector (SPK) on the system board.

**i NOTE:** To disconnect the speaker cable from the connector on the system board, pry up the bottom side of the cable connector's head first and then pull it away from the connector (SPK) on the system board. DO NOT pull the cable downwards to disconnect the speaker cable from the system board.



2. Unroute and remove the speaker cable from the routing guides on palm-rest and keyboard assembly.
3. Lift the speakers, along with the cable, off the palm-rest and keyboard assembly.

## Installing the speakers

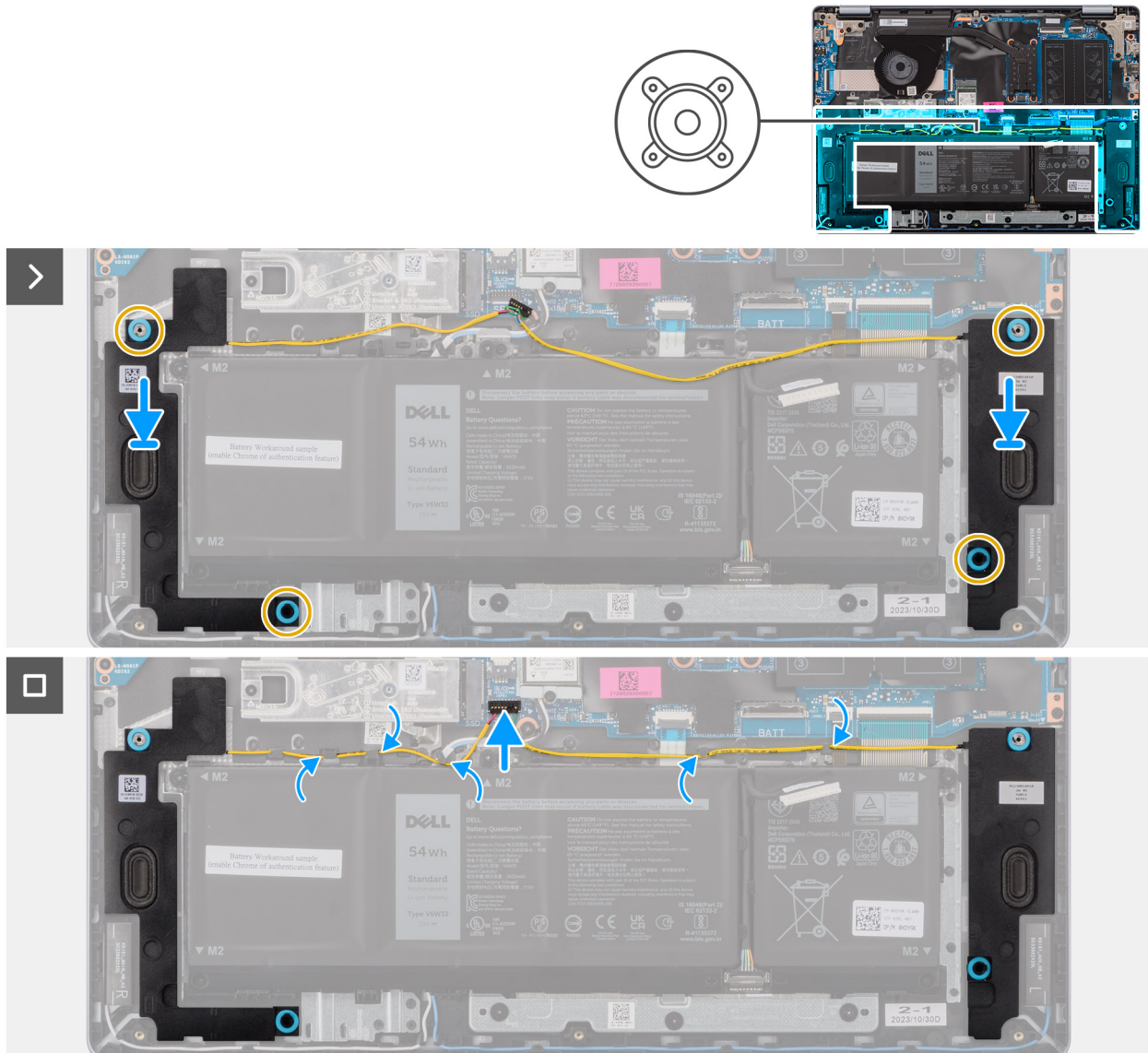
### Prerequisites

If you are replacing a component, remove the existing component before performing the installation procedure.

### About this task

**NOTE:** If the rubber grommets are pushed out when removing the speakers, push them back in before replacing the speakers.

The following image indicates the location of the speakers and provides a visual representation of the installation procedure.



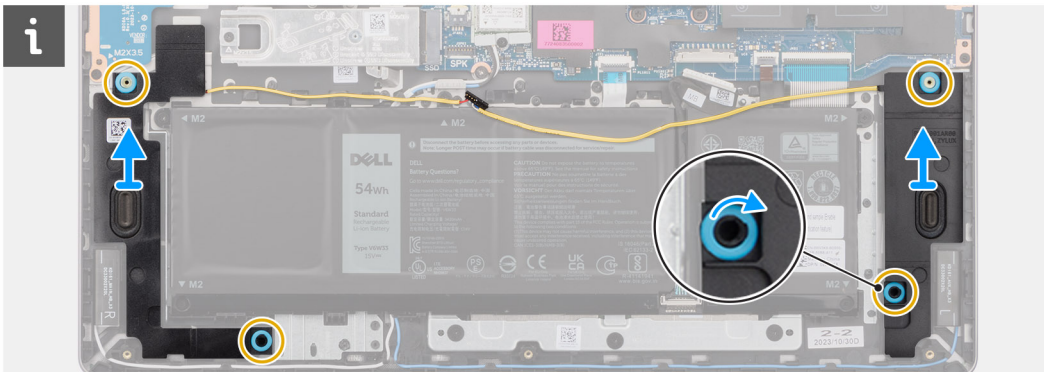
**Figure 17. Installing the speakers**

**Steps**

1. **NOTE:** If the rubber grommets are pushed out when removing the speakers, push them back in before replacing the speakers.

Using the alignment posts and rubber grommets, place the speakers in the slots on the palm-rest and keyboard assembly.

1. **NOTE:** Ensure that the alignment posts are threaded through the rubber grommets on the speakers. After placing speakers on the palm-rest and keyboard assembly, ensure that rubber grommets are seated into the slot and installed on the speakers properly.



2. Route the speaker cable along the bottom side of the palm-rest and keyboard assembly, over the wireless-antenna cables. Then secure the speaker cable into the routing guides on the palm-rest and keyboard assembly.

**i** **NOTE:** The speaker cable must be routed through the routing guides to avoid damaging the speaker cable when installing the base cover.

3. Connect the speaker cable to its connector (SPK) on the system board.

### Next steps

1. Install the [base cover](#).
2. Follow the procedure in [After working inside your computer](#).

## Fan

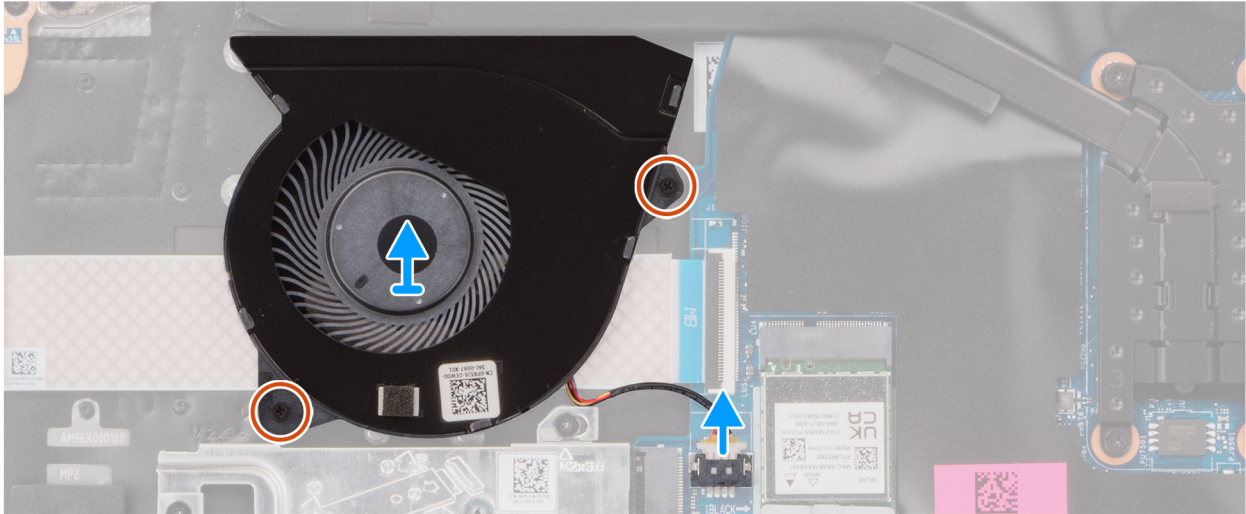
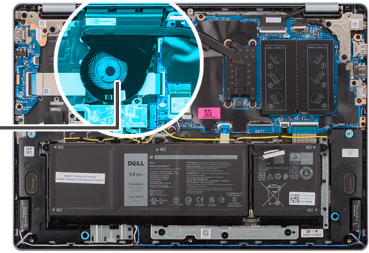
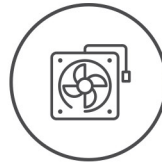
### Removing the fan

#### Prerequisites

1. Follow the procedure in [Before working inside your computer](#).
2. Remove the [base cover](#).

#### About this task

The following image indicates the location of the fan and provides a visual representation of the removal procedure.



**Figure 18. Removing the fan**

### Steps

1. Disconnect the fan cable from its connector (FAN) on the system board.
2. Remove the two screws (M2x5.5) that secure the fan to the palm-rest and keyboard assembly.
3. Lift the fan, along with the fan cable, off the palm-rest and keyboard assembly.

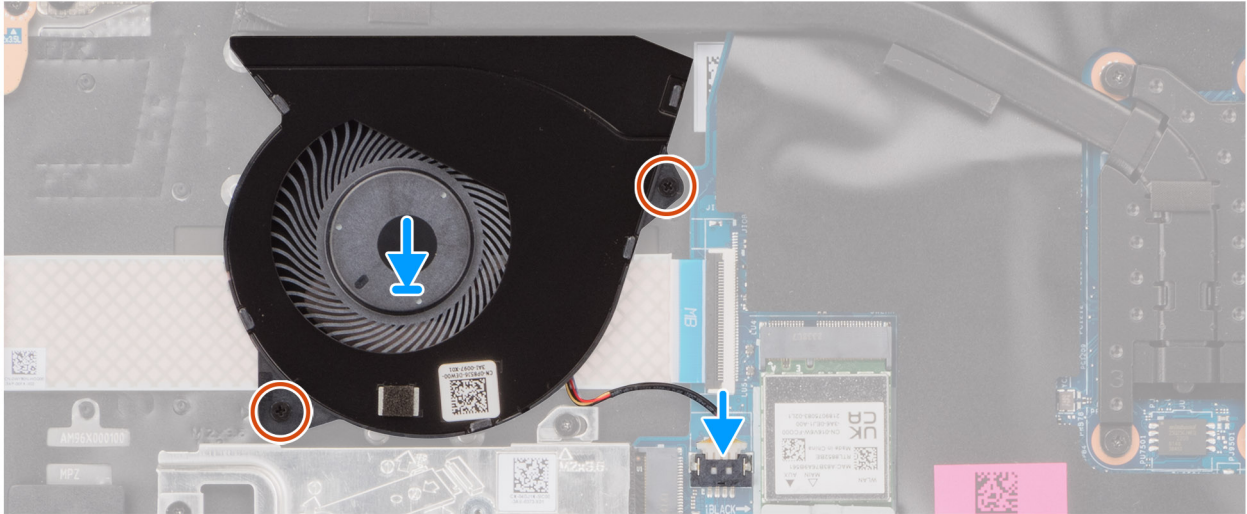
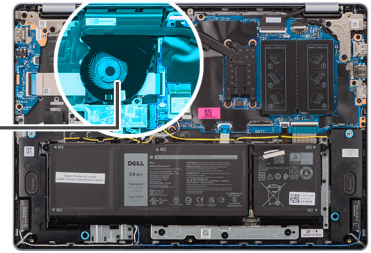
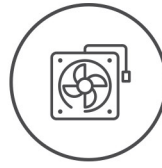
## Installing the fan

### Prerequisites

If you are replacing a component, remove the existing component before performing the installation procedure.

### About this task

The following image indicates the location of the fan and provides a visual representation of the installation procedure.



**Figure 19. Installing the fan**

#### **Steps**

1. Place and align the fan, along with fan cable, in the slot on the palm-rest and keyboard assembly.
2. Align the screw holes on the fan to the screw holes on the palm-rest and keyboard assembly.
3. Replace the two screws (M2x5.5) that secure the fan to the palm-rest and keyboard assembly.
4. Connect the fan cable to its connector (FAN) on the system board.

#### **Next steps**

1. Install the [base cover](#).
2. Follow the procedure in [After working inside your computer](#).

# Removing and installing Field Replaceable Units (FRUs)

The replaceable components in this chapter are Field Replaceable Units (FRUs).

**CAUTION:** The information in this section is intended for authorized service technicians only.

**CAUTION:** To avoid any potential damage to the component or loss of data, ensure that an authorized service technician replaces the Field Replaceable Units (FRUs).

**CAUTION:** Dell Technologies recommends that this set of repairs, if needed, to be conducted by trained technical repair specialists.

**CAUTION:** As a reminder, your warranty does not cover damages that may occur during FRU repairs that are not authorized by Dell Technologies.

**NOTE:** The images in this document may differ from your computer depending on the configuration you ordered.

## Battery

### Rechargeable Li-ion battery precautions

**CAUTION:**

- Exercise caution when handling rechargeable Li-ion batteries.
- Discharge the battery completely before removing it. Disconnect the AC power adapter from the computer and operate the computer solely on battery power—the battery is fully discharged when the computer no longer turns on when the power button is pressed.
- Do not crush, drop, mutilate, or penetrate the battery with foreign objects.
- Do not expose the battery to high temperatures, or disassemble battery packs and cells.
- Do not apply pressure to the surface of the battery.
- Do not bend the battery.
- Do not use tools of any kind to pry on or against the battery.
- Ensure any screws during the servicing of this product are not lost or misplaced, to prevent accidental puncture or damage to the battery and other computer components.
- If the battery gets stuck inside your computer as a result of swelling, do not try to release it as puncturing, bending, or crushing a rechargeable Li-ion battery can be dangerous. In such an instance, contact Dell technical support for assistance. See [Contact Support at Dell Support Site](#).
- Always purchase genuine batteries from [Dell Site](#) or authorized Dell partners and resellers.
- Swollen batteries should not be used and should be replaced and disposed properly. For guidelines on how to handle and replace swollen rechargeable Li-ion batteries, see [Handling swollen rechargeable Li-ion batteries](#).

### Removing the battery

**CAUTION:** The information in this section is intended for authorized service technicians only.

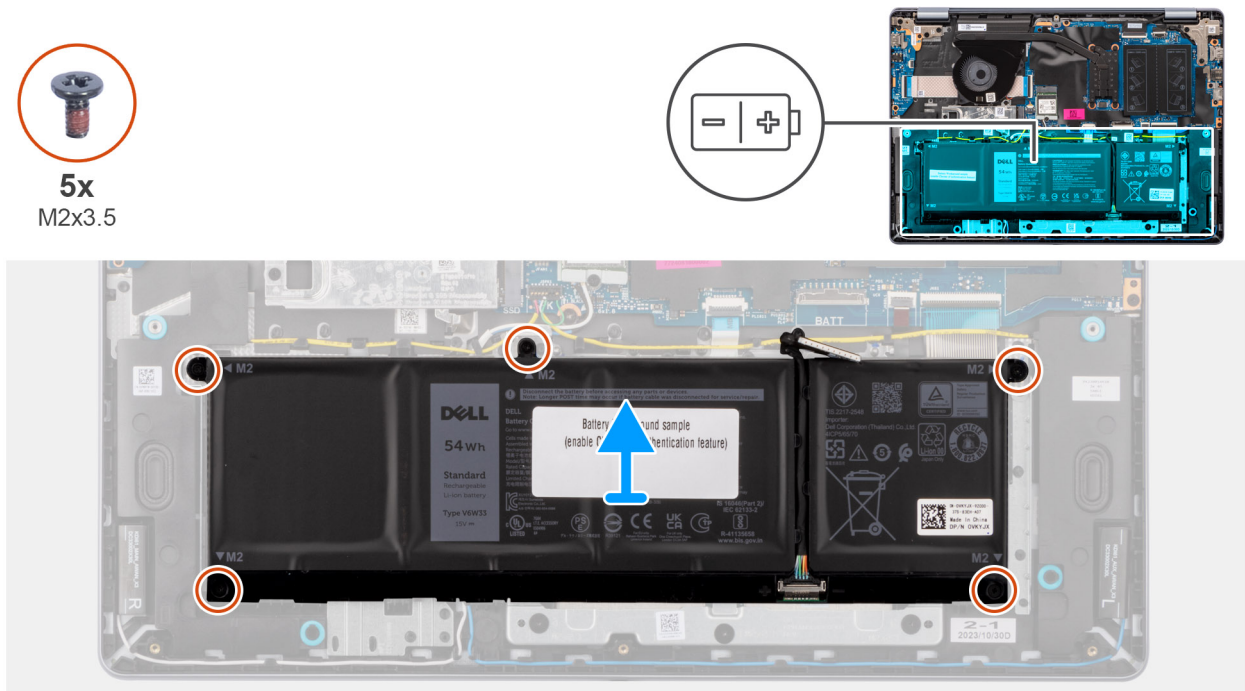
## Prerequisites

1. Follow the procedure in [Before working inside your computer](#).
2. Remove the [base cover](#).

## About this task

The following image indicates the location of the battery and provides a visual representation of the removal procedure.

- NOTE:** Inspiron 16 5645 supports the following:
- 4-cell, 54 Wh, Lithium Ion Polymer, ExpressCharge Capable
  - 4-cell, 64 Wh, Lithium Ion Polymer, ExpressCharge Capable



**Figure 20. Removing the battery**

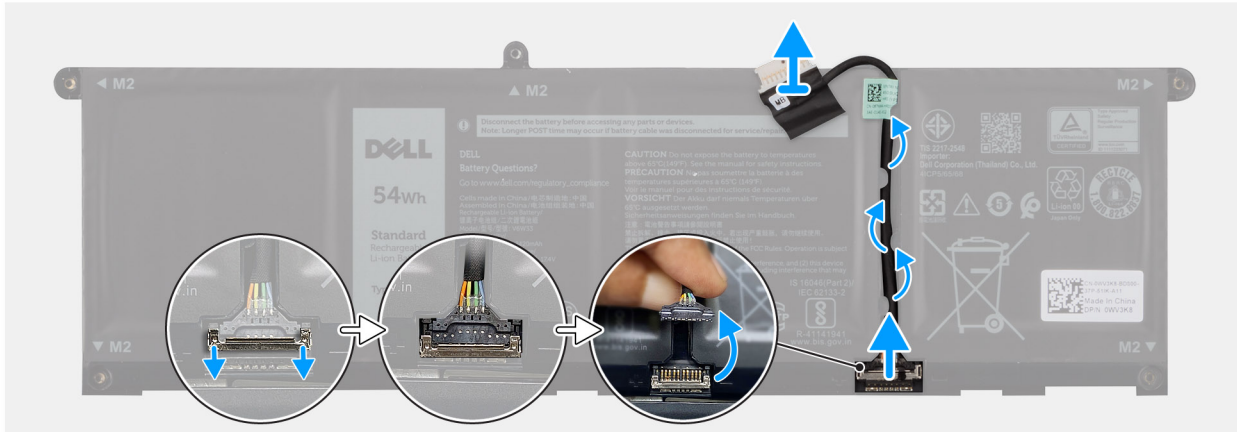
## Steps

1. Remove the five screws (M2x3.5) that secure the battery to the palm-rest and keyboard assembly.
2. Lift the battery, along with the battery cable, off the palm-rest and keyboard assembly.

## Disconnecting the battery cable

**CAUTION:** The information in this section is intended for authorized service technicians only.

## Prerequisites



1. Follow the procedure in [Before working inside your computer](#).
2. Remove the [base cover](#).
3. Remove the [battery](#).

### About this task

The following image indicates the location of the battery cable and provides a visual representation of the removal procedure.

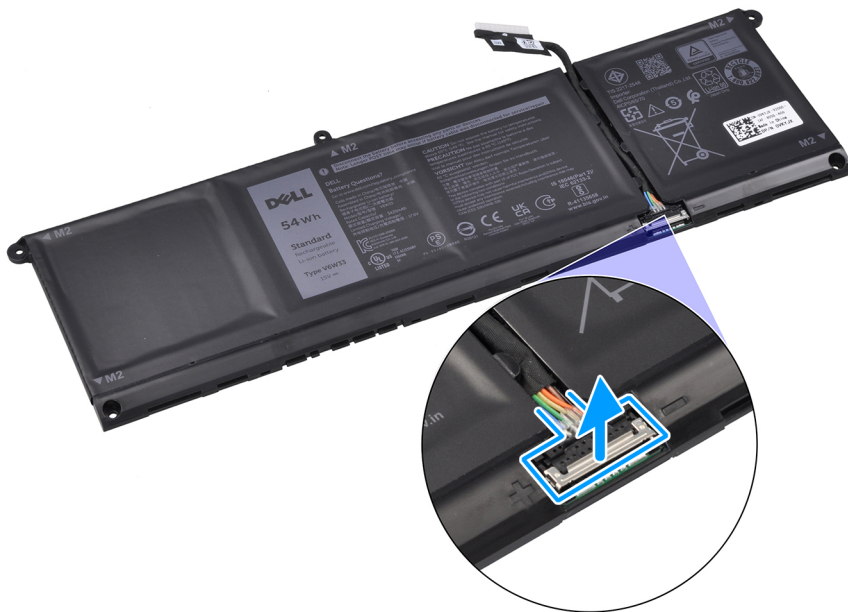
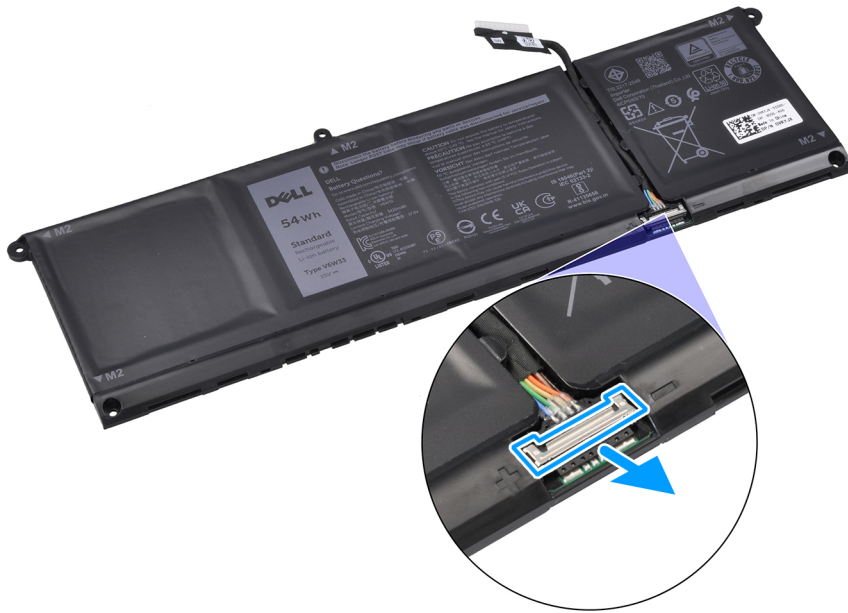
**Figure 21. Disconnecting the battery cable**

### Steps

1. Remove the battery cable from the routing guides on the battery. To disconnect the battery cable, first push the latch downward to release the connector, and then pull the connector upward to disconnect it from the battery.
2. Open the latch and disconnect the battery cable from the connector on the battery.

**NOTE:** To disconnect the battery cable, first push the latch downward to release the connector, and then pull the connector upward to disconnect it from the battery.

**CAUTION:** DO NOT disconnect the battery cable from the battery by pulling the battery cable. This may damage the battery or the battery cable.



## Connecting the battery cable

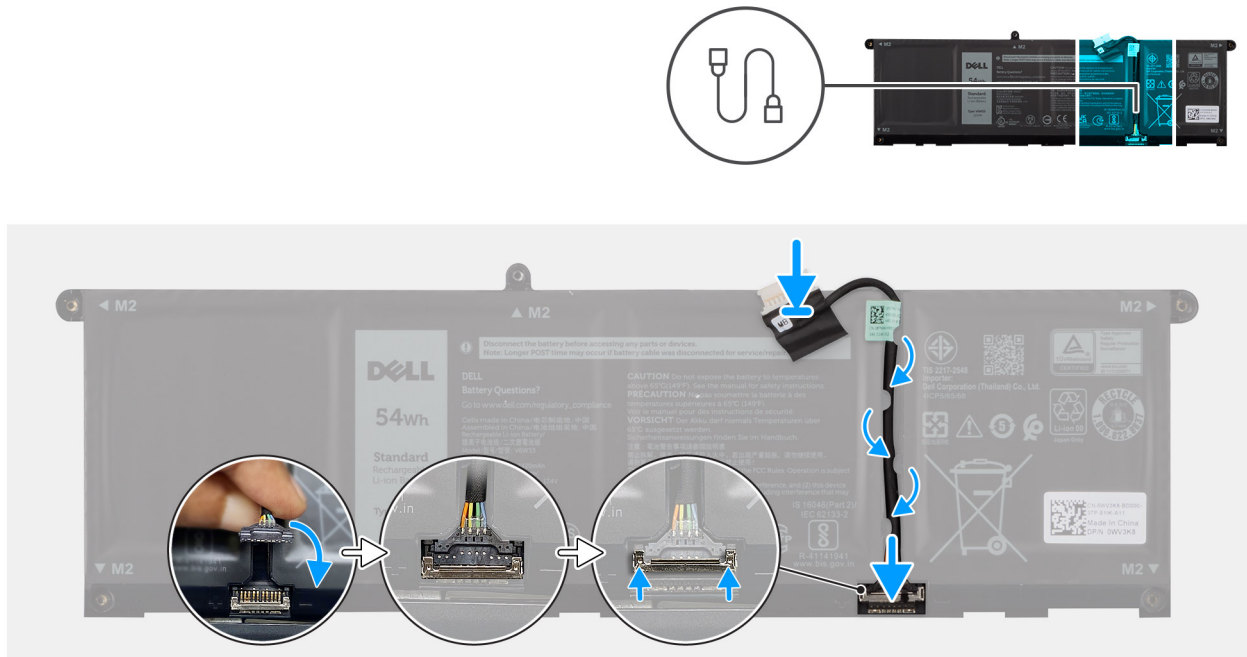
**CAUTION:** The information in this section is intended for authorized service technicians only.

### Prerequisites

If you are replacing a component, remove the existing component before performing the installation procedure.

### About this task

The following image indicates the location of the battery cable and provides a visual representation of the installation procedure.



**Figure 22. Connecting the battery cable**

**Steps**

1. Connect the battery cable to the connector on the battery and close the latch.
2. Route the battery cable through the routing guides on the battery.

**Next steps**

1. Install the [battery](#).
2. Install the [base cover](#).
3. Follow the procedure in [After working inside your computer](#).

## Installing the battery

**CAUTION:** The information in this section is intended for authorized service technicians only.

**Prerequisites**

If you are replacing a component, remove the existing component before performing the installation procedure.

**About this task**

The following image indicates the location of the battery and provides a visual representation of the installation procedure.

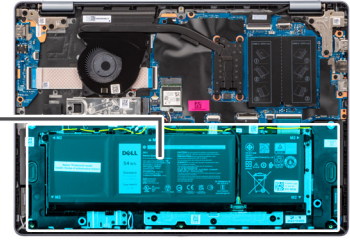
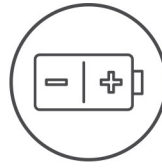
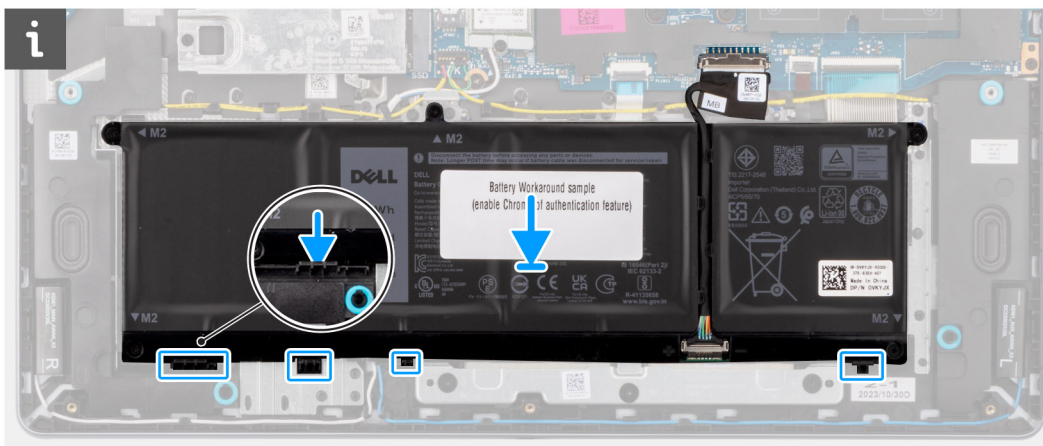


Figure 23. Installing the battery

### Steps

1. Place the battery, along with the battery cable, in the slot on the palm-rest and keyboard assembly.
2. Align the screw holes on the battery to the screw holes on the palm-rest and keyboard assembly.

**i** **NOTE:** While installing the battery, insert the cut-outs on the battery into the hooks on the palm-rest and keyboard assembly.



3. Replace the five screws (M2x3.5) that secure the battery to the palm-rest and keyboard assembly.

### Next steps

1. Install the [base cover](#).
2. Follow the procedure in [After working inside your computer](#).

# Heat sink

## Removing the heat sink

**CAUTION:** The information in this section is intended for authorized service technicians only.

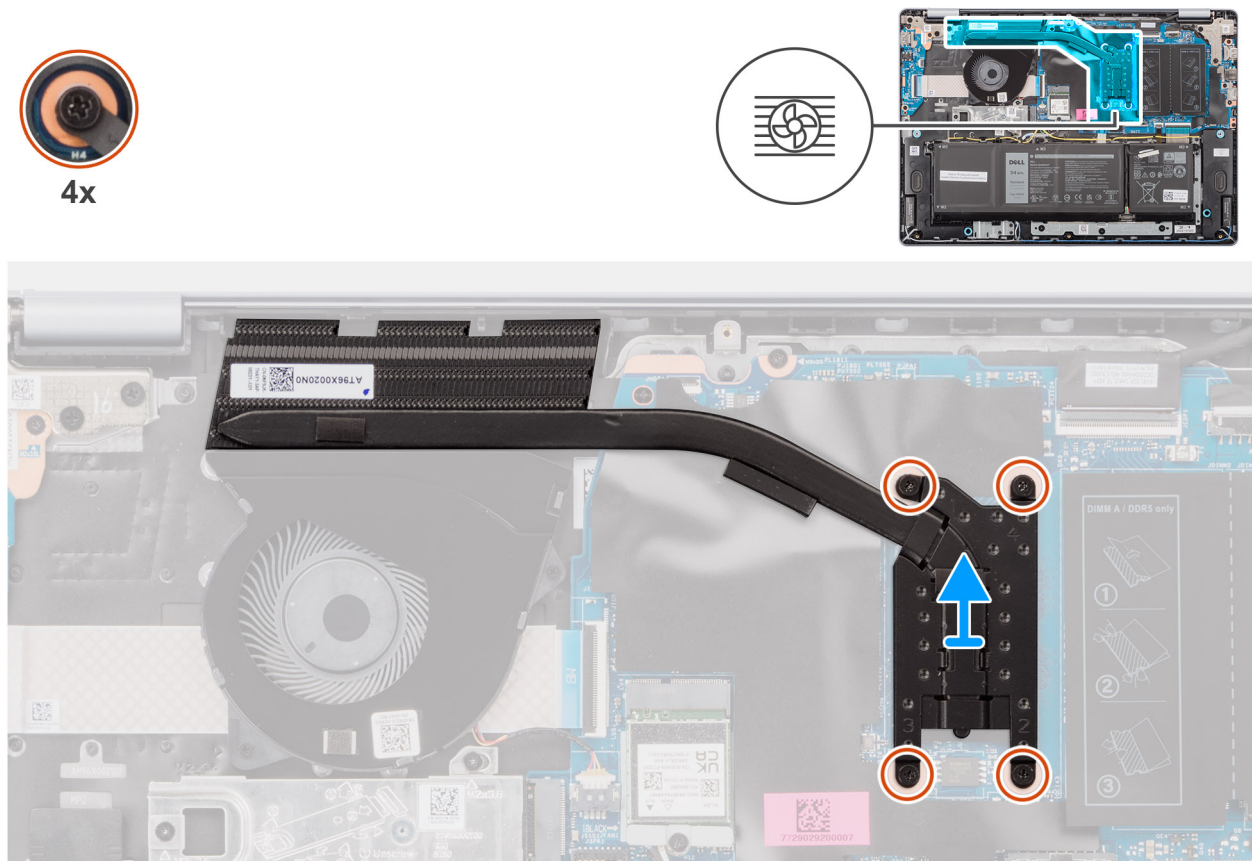
### Prerequisites

1. Follow the procedure in [Before working inside your computer](#).
2. Remove the [base cover](#).

### About this task

- NOTE:** The heat sink may become hot during normal operation. Allow sufficient time for the heat sink to cool before you touch it.
- NOTE:** For maximum cooling of the processor, do not touch the heat transfer areas on the heat sink. The oils in your skin can reduce the heat transfer capability of the thermal grease.

The following image indicates the location of the heat sink and provides a visual representation of the removal procedure.



**Figure 24. Removing the heat sink**

### Steps

1. Loosen the four captive screws that secure the heat sink to the system board.
  - NOTE:** Loosen the four captive screws in the reverse sequential order indicated on the heat sink [4 → 3 → 2 → 1].
2. Lift the heat sink off the system board.

## Installing the heat sink

**CAUTION:** The information in this section is intended for authorized service technicians only.

### Prerequisites

If you are replacing a component, remove the existing component before performing the installation procedure.

### About this task

**NOTE:** If either the system board or the heat sink is replaced, use the thermal grease that is provided in the kit to ensure that thermal conductivity is achieved.

The following image indicates the location of the heat sink and provides a visual representation of the installation procedure.

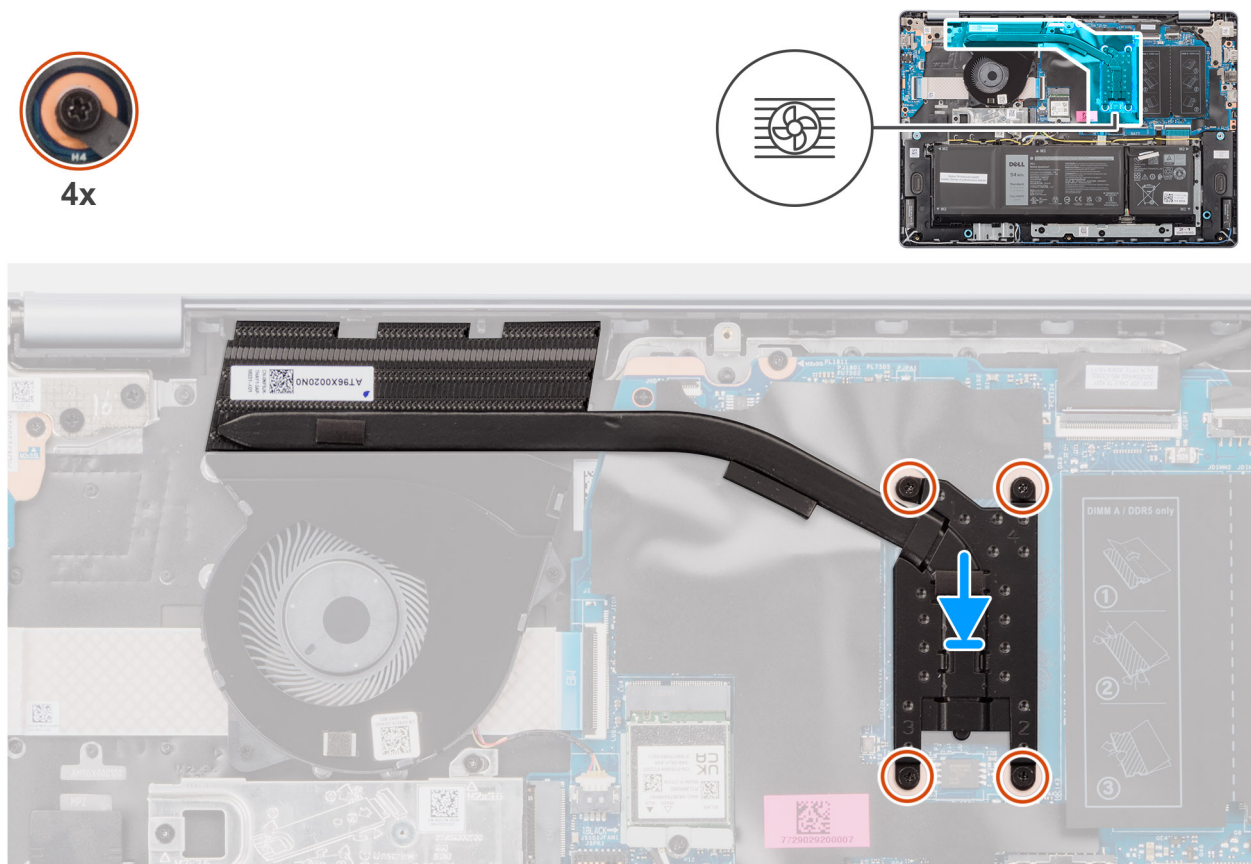


Figure 25. Installing the heat sink

### Steps

1. Place the heat sink in the slot on the system board.
2. Align the screw holes on the heat sink to the screw holes on the system board.
3. Tighten the four captive screws that secure the heat sink to the system board.

**NOTE:** Tighten the four captive screws in the sequential order indicated on the heat sink [1 → 2 → 3 → 4].

### Next steps

1. Install the [base cover](#).
2. Follow the procedure in [After working inside your computer](#).

# Touchpad

## Removing the touchpad assembly

**CAUTION:** The information in this section is intended for authorized service technicians only.

### Prerequisites

1. Follow the procedure in [Before working inside your computer](#).
2. Remove the [base cover](#).
3. Remove the [battery](#).

### About this task

The following images indicate the location of the touchpad assembly and provide a visual representation of the removal procedure.

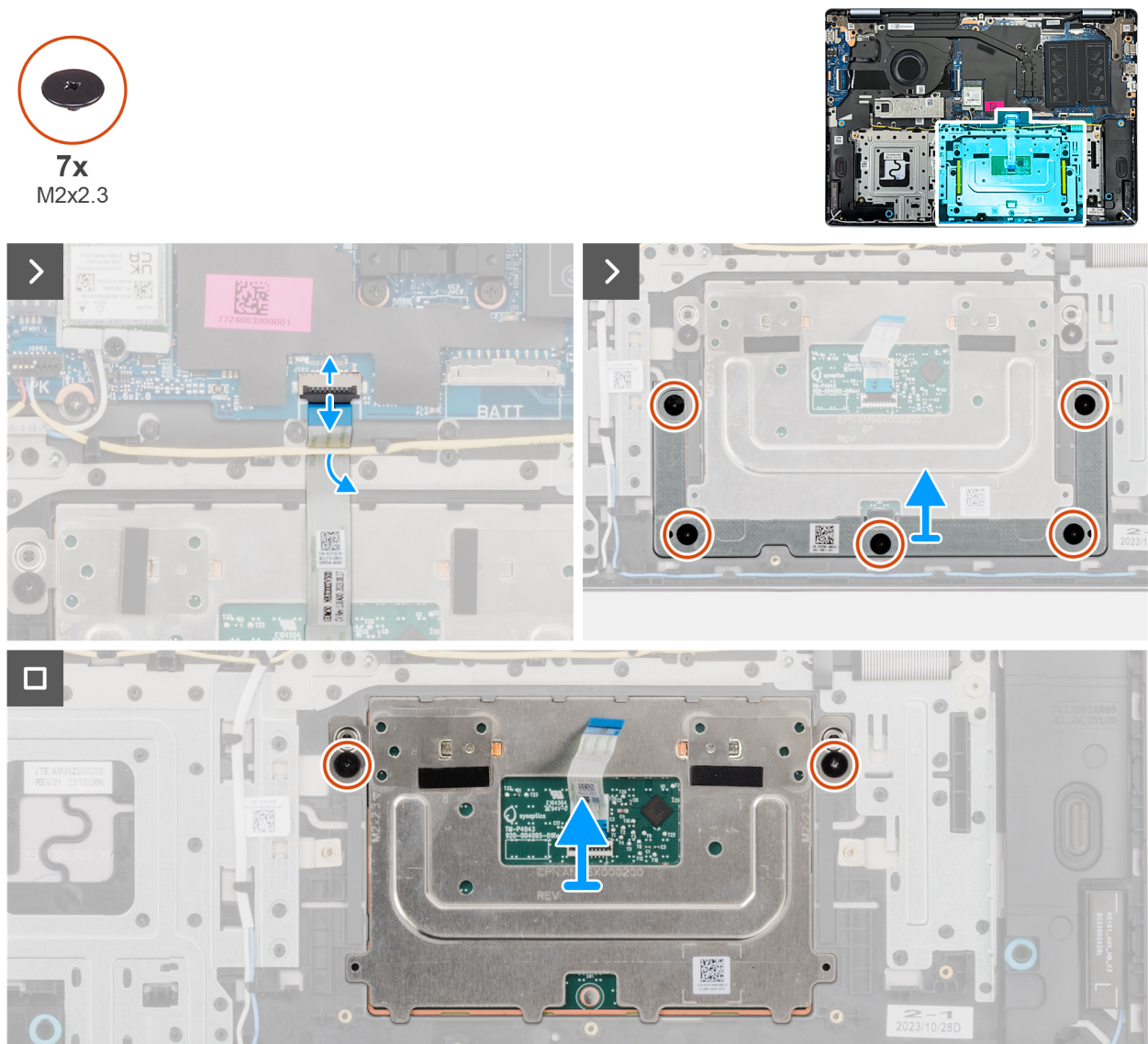


Figure 26. Removing the touchpad assembly

## Steps

1. Open the latch and disconnect the touchpad cable from its connector (TP) on the system board.
2. Remove the five screws (M2x2.3) that secure the touchpad bracket to the palm-rest and keyboard assembly.
3. Slide and lift the touchpad bracket off the touchpad assembly.
4. Remove the two screws (M2x2.3) that secure the touchpad assembly to the palm-rest and keyboard assembly.
5. Lift the touchpad assembly, along with the touchpad cable, off the palm-rest and keyboard assembly.


## Installing the touchpad assembly

 **CAUTION:** The information in this section is intended for authorized service technicians only.

### Prerequisites

If you are replacing a component, remove the existing component before performing the installation procedure.

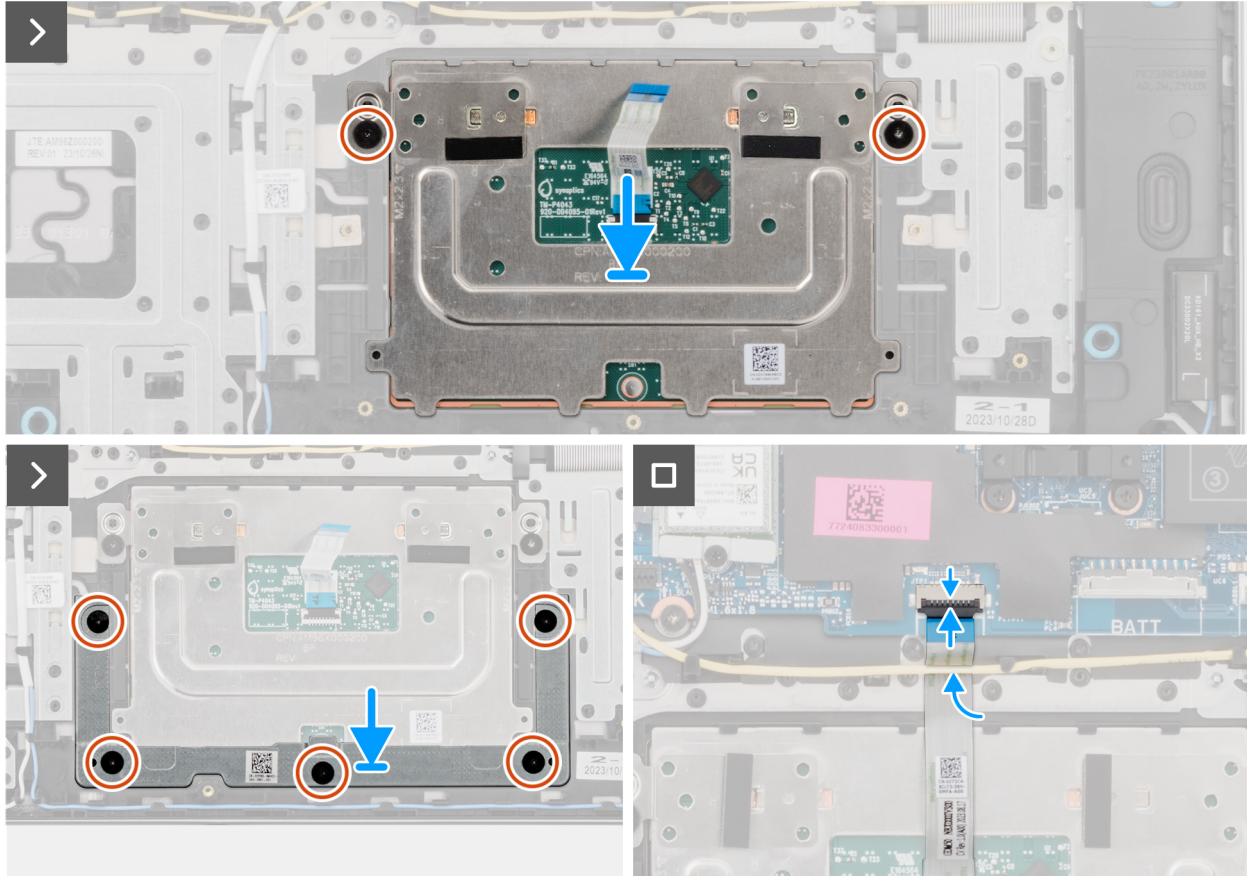
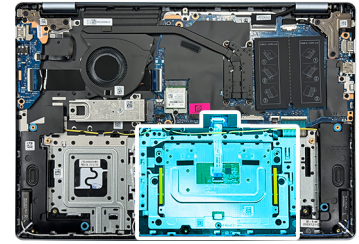
### About this task

 **NOTE:** Ensure that the touchpad is aligned with the guides available on the palm-rest and keyboard assembly, and the gap on either sides of the touchpad is equal.

The following images indicate the location of the touchpad assembly and provide a visual representation of the installation procedure.



7x  
M2x2.3



**Figure 27. Installing the touchpad assembly**

**Steps**

1. Align and place the touchpad, along with the touchpad cable, in the slot on the palm-rest and keyboard assembly.
2. Replace the two screws (M2x2.3) that secure the touchpad assembly to the palm-rest and keyboard assembly.
3. Place the touchpad bracket in the slot on the palm-rest and keyboard assembly.
4. Align the screw holes on the touchpad bracket to the screw holes on the palm-rest and keyboard assembly.
5. Replace the five screws (M2x2.3) that secure the touchpad bracket to the palm-rest and keyboard assembly.
6. Connect the touchpad cable to its connector (TP) on the system board and close the latch.

**Next steps**

1. Install the [battery](#).
2. Install the [base cover](#).
3. Follow the procedure in [After working inside your computer](#).

# Display assembly

## Removing the display assembly

 **CAUTION:** The information in this section is intended for authorized service technicians only.

 **CAUTION:** The maximum operating angle for the display-panel hinge is 135 degrees.

### Prerequisites

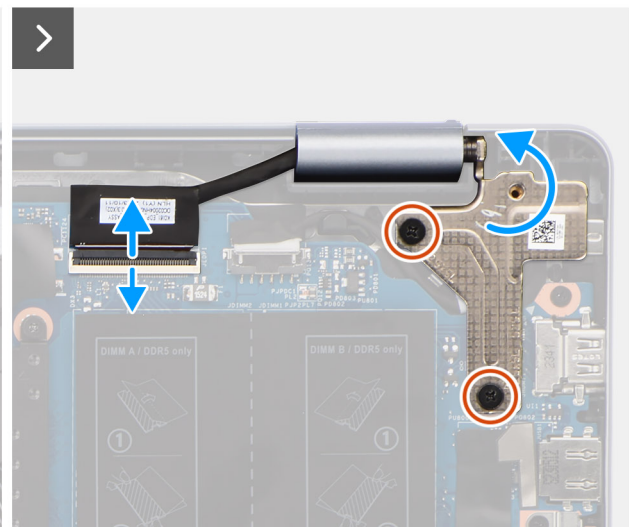
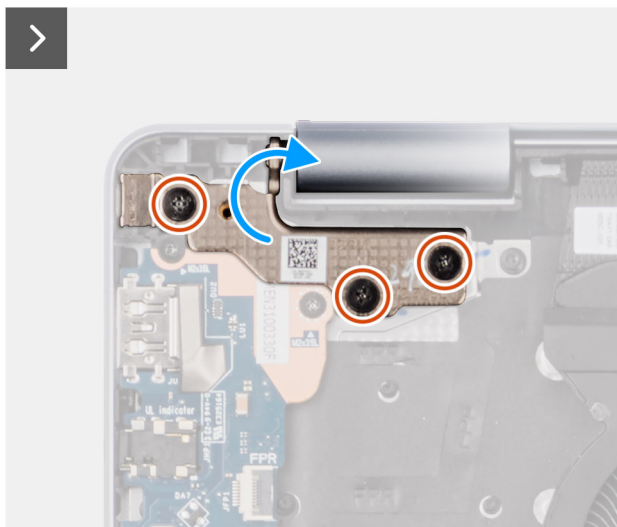
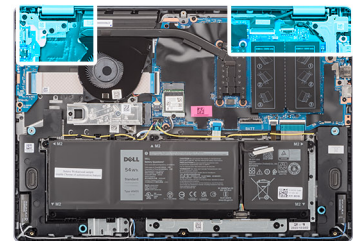
1. Follow the procedure in [Before working inside your computer](#).
2. Remove the [base cover](#).

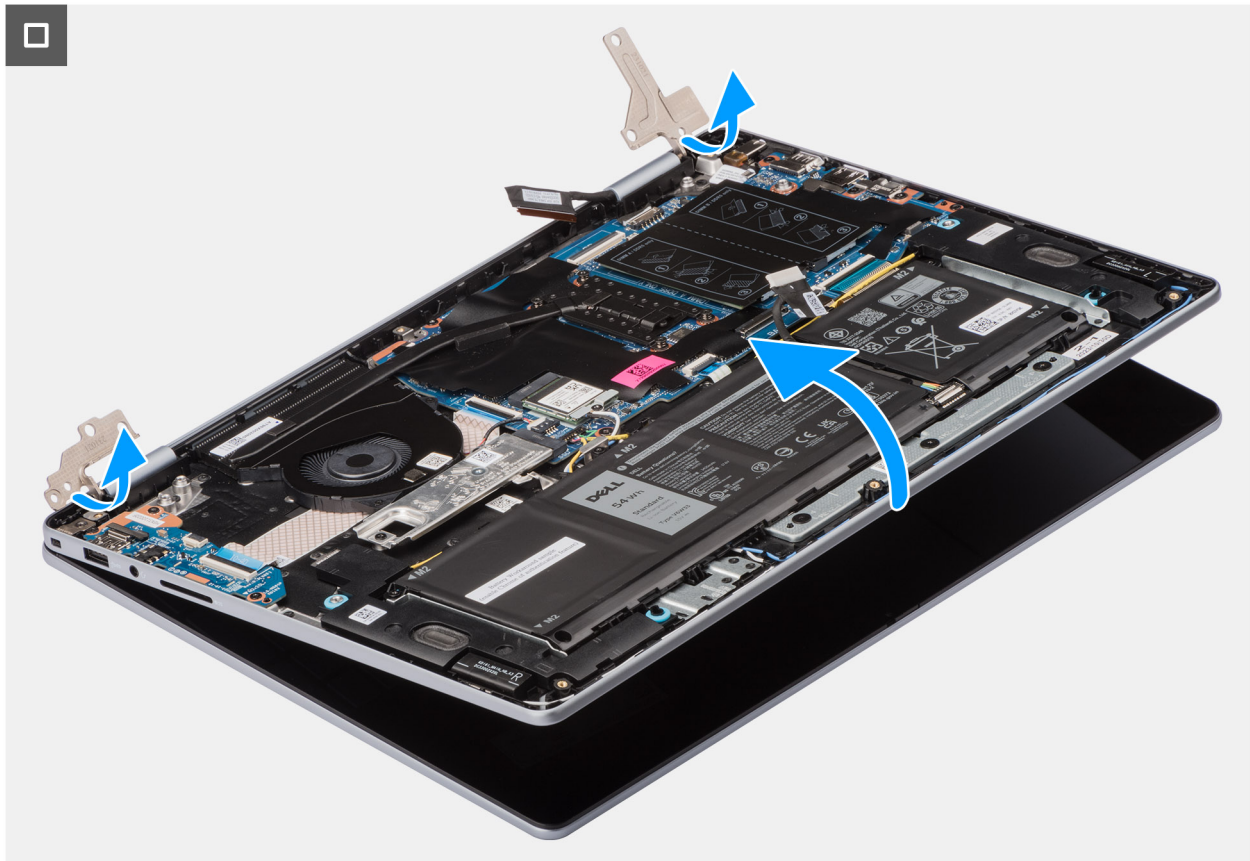
### About this task

The following images indicate the location of the display assembly and provide a visual representation of the removal procedure.



**5x**  
M2.5x5





**Figure 28. Removing the display assembly**

### Steps

1. Remove the five screws (M2.5x5) that secure the display hinges to the palm-rest and keyboard assembly.
2. Disconnect the display cable from its connector (eDP) on the system board.
3. Remove the display cable from the routing guides on the palm-rest and keyboard assembly.
4. Open the hinges to a 90-degree angle and place the computer on the edge of a flat surface.
5. Lift the palm-rest and keyboard assembly at an angle to free it from the hinges and remove it from the display assembly.

**i** **NOTE:** The display assembly is a Hinge-Up Design (HUD) assembly and cannot be further disassembled. If any components in the display assembly malfunction and requires replacement, the entire display assembly has to be replaced.

**i** **NOTE:** The power-adaptor port is secured in place by the left hinge. There is no screw, tape, or adhesive securing the power-adaptor port to the palm-rest. Technicians should ensure that the power-adaptor port has not fallen out when the left hinge is removed.

## Installing the display assembly

**⚠ CAUTION:** The information in this section is intended for authorized service technicians only.

**⚠ CAUTION:** The maximum operating angle for the display-panel hinge is 135 degrees.

### Prerequisites

If you are replacing a component, remove the existing component before performing the installation procedure.

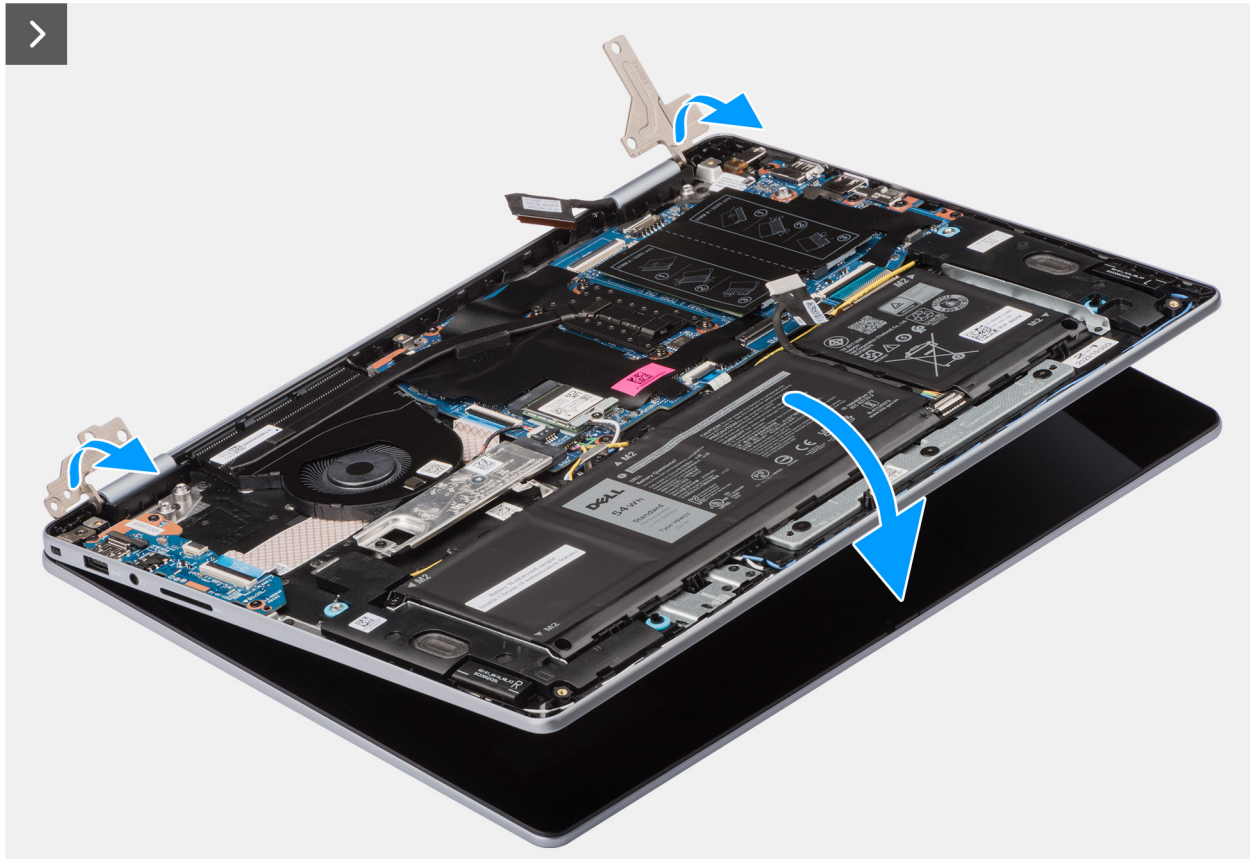
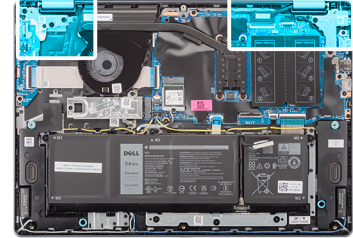
### About this task

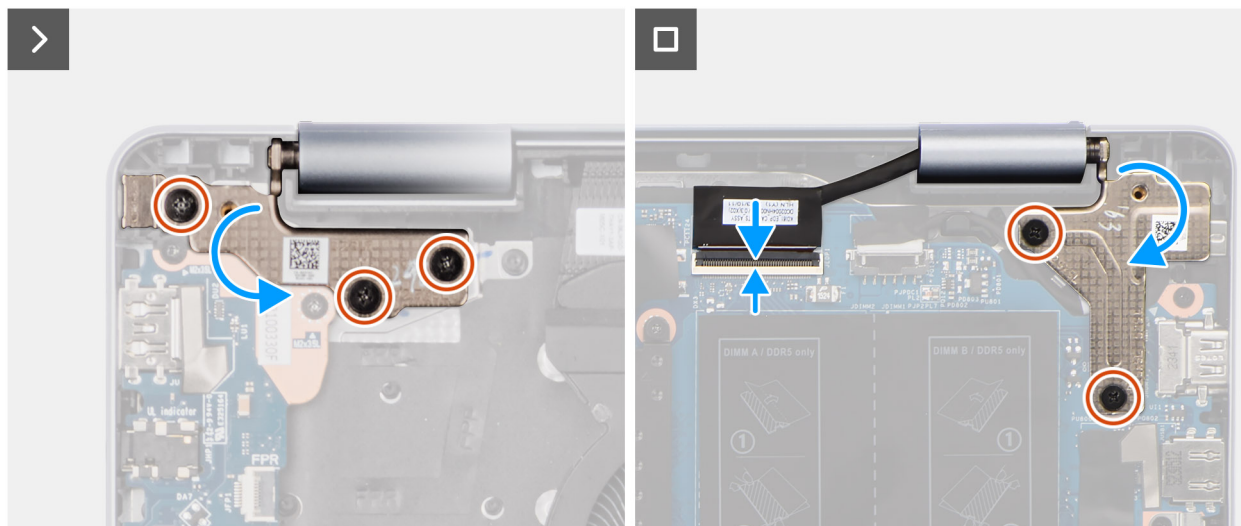
**NOTE:** Ensure that the display hinges are opened to the maximum before replacing the display assembly on the palm-rest and keyboard assembly.

The following images indicate the location of the display assembly and provide a visual representation of the installation procedure.



**5x**  
M2.5x5





**Figure 29. Installing the display assembly**

### Steps

1. Place the display assembly on a clean and flat surface.
2. Slide the palm-rest and keyboard assembly at an angle and place the palm-rest and keyboard assembly on the display assembly.
  - NOTE:** The power-adaptor port is secured in place by the left hinge. There is no screw, tape, or adhesives securing the power-adaptor port to the palm-rest. Technicians should ensure that the power-adaptor port has not fallen out when the left hinge is removed.
3. Gently press down on the hinges to align the screw holes on the hinges with the screw holes on the palm-rest and keyboard assembly.
4. Connect the display cable to its connector (eDP) on the system board.
5. Replace the five screws (M2.5x5) that secure the display assembly to the palm-rest and keyboard assembly.

### Next steps

1. Install the [base cover](#).
2. Follow the procedure in [After working inside your computer](#).

## I/O-board cable

### Removing the I/O-board cable

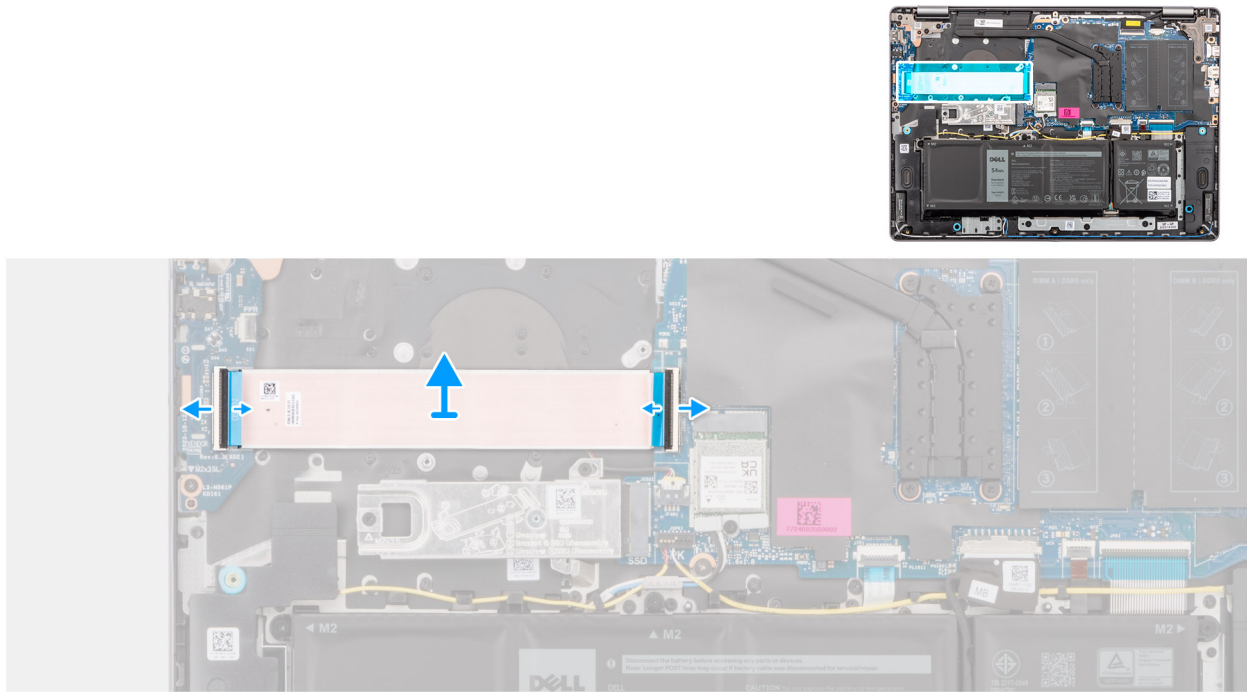
**CAUTION:** The information in this section is intended for authorized service technicians only.

#### Prerequisites

1. Follow the procedure in [Before working inside your computer](#).
2. Remove the [base cover](#).
3. Remove the [fan](#).

#### About this task

The following image indicates the location of the I/O-board cable and provides a visual representation of the removal procedure.



**Figure 30. Removing the I/O-board cable**

### Steps

1. Open the latch and disconnect the I/O-board cable from its connector (IO) on the system board.
2. Open the latch and disconnect the I/O-board cable from its connector on the I/O board.
3. Remove the I/O-board cable from the palm-rest and keyboard assembly.

## Installing the I/O-board cable

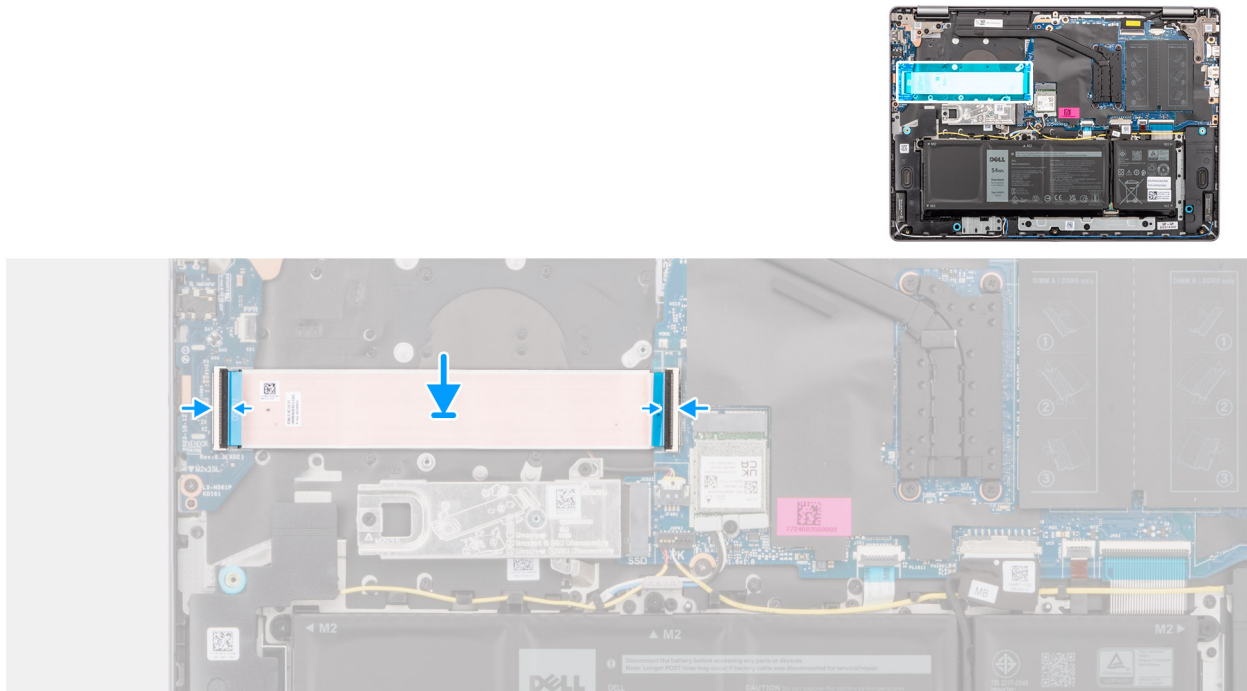
**CAUTION:** The information in this section is intended for authorized service technicians only.

### Prerequisites

If you are replacing a component, remove the existing component before performing the installation procedure.

### About this task

The following image indicates the location of the I/O-board cable and provides a visual representation of the installation procedure.



**Figure 31. Installing the I/O-board cable**

### Steps

1. Place the I/O-board cable on the palm-rest and keyboard assembly.
2. Connect the I/O-board cable to its connector on the I/O board and close the latch.
3. Connect the I/O-board cable to its connector (IO) on the system board and close the latch.

### Next steps

1. Install the [fan](#).
2. Install the [base cover](#).
3. Follow the procedure in [After working inside your computer](#).

## I/O board

### Removing the I/O board

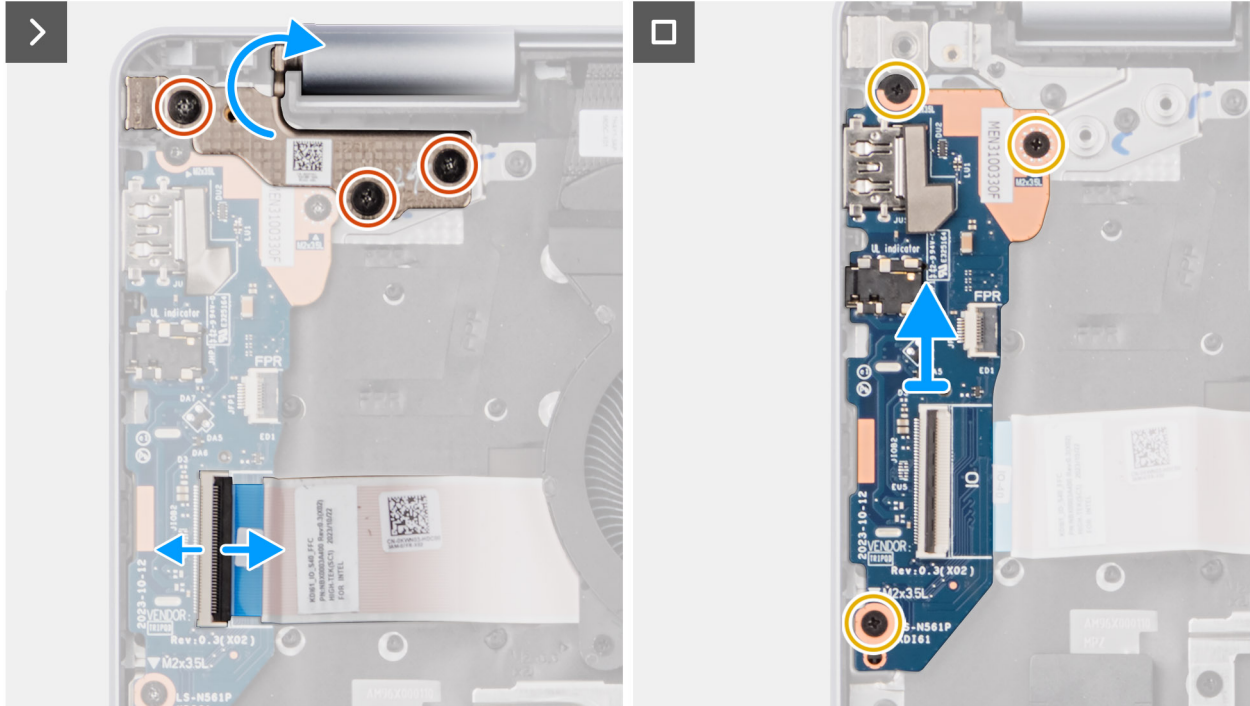
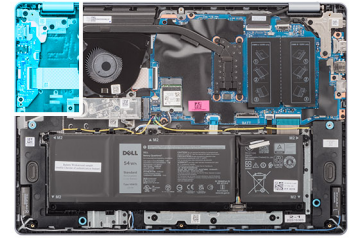
**CAUTION:** The information in this section is intended for authorized service technicians only.

#### Prerequisites

1. Follow the procedure in [Before working inside your computer](#).
2. Remove the [base cover](#).

#### About this task

The following images indicate the location of the I/O board and provide a visual representation of the removal procedure.



**Figure 32. Removing the I/O board**

**Steps**

1. Remove the three screws (M2.5x5) that secure the hinge to the palm-rest and keyboard assembly.
2. Pry open the hinge away from the palm-rest and keyboard assembly to access the I/O board.
3. Open the latch and disconnect the I/O-board cable from its connector on the I/O board.
4. Open the latch and disconnect the fingerprint reader cable from the I/O board.

**NOTE:** This step applies only to computers shipped with a fingerprint reader installed.

5. Remove the three screws (M2x3.5) that secure the I/O board to the palm-rest and keyboard assembly.
6. Carefully slide and remove the I/O board at angle, from the palm-rest and keyboard assembly.

## Installing the I/O board

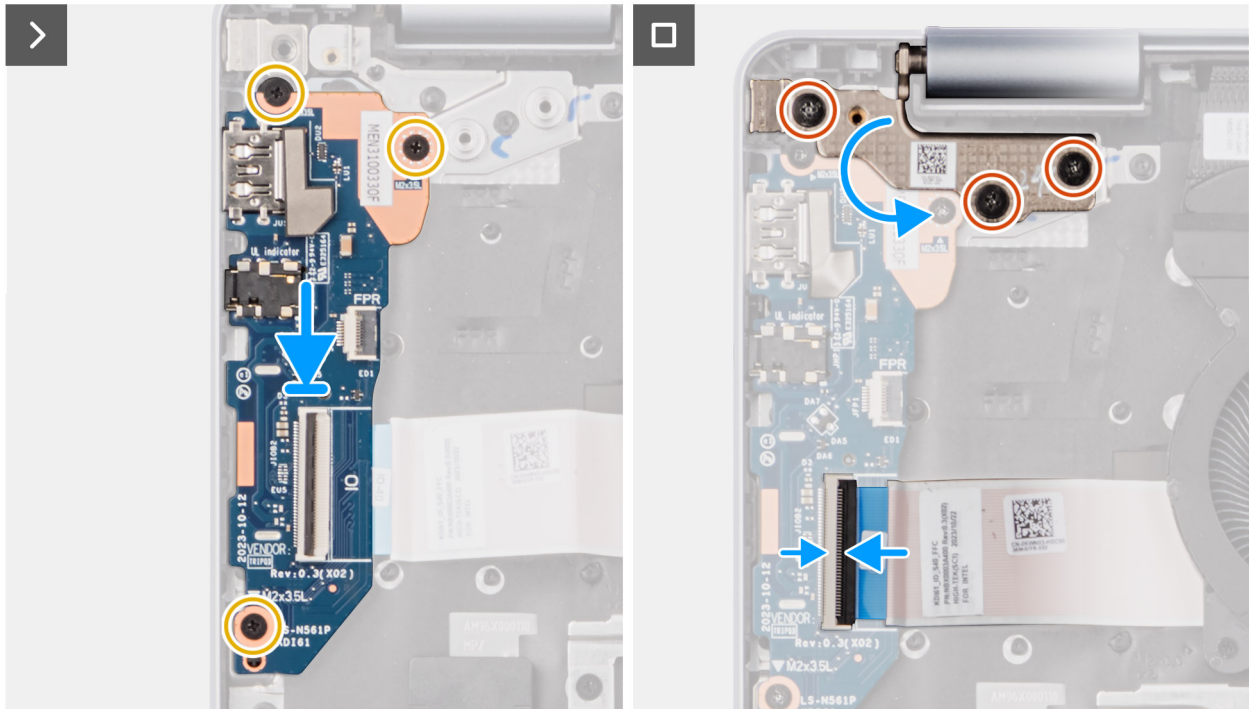
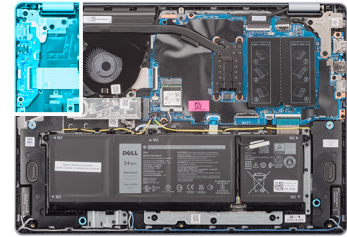
**CAUTION:** The information in this section is intended for authorized service technicians only.

**Prerequisites**

If you are replacing a component, remove the existing component before performing the installation procedure.

**About this task**

The following images indicate the location of the I/O board and provide a visual representation of the installation procedure.



**Figure 33. Installing the I/O board**

**Steps**

1. Align the ports on the I/O board to the port openings on the palm-rest and keyboard assembly.
2. Carefully slide and place the I/O board at an angle, on the palm-rest and keyboard assembly.
3. Align the screw holes on the I/O board to the screw holes on the palm-rest and keyboard assembly.
4. Replace the three screws (M2x3.5) that secure the I/O board to the palm-rest and keyboard assembly.
5. Connect the fingerprint reader cable to the connector on the I/O board and close the latch.

**NOTE:** This step applies only to computers shipped with a fingerprint reader installed.

6. Connect the I/O-board cable to the connector on the I/O board and close the latch.
7. Close the display hinge downwards to align the screw holes of the left hinge to the screw holes on the palm-rest and keyboard assembly.
8. Replace the three screws (M2.5x5) that secure the hinge to the palm-rest and keyboard assembly.

**Next steps**

1. Install the [base cover](#).
2. Follow the procedure in [After working inside your computer](#).

# Power button

## Removing the power button

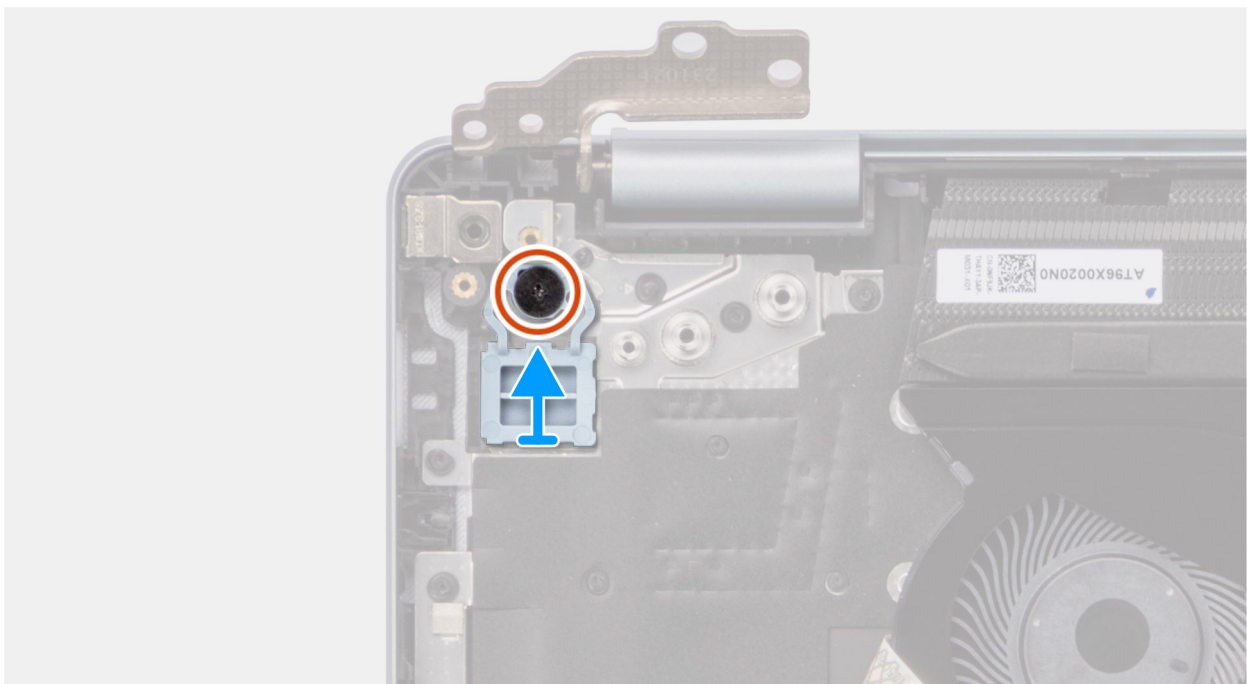
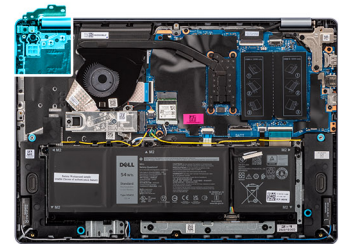
**CAUTION:** The information in this section is intended for authorized service technicians only.

### Prerequisites

1. Follow the procedure in [Before working inside your computer](#).
2. Remove the [base cover](#).
3. Remove the [I/O board](#).

### About this task

The following image indicates the location of the power button and provides a visual representation of the removal procedure.



**Figure 34. Removing the power button**

### Steps

1. Remove the screw (M2x2.3) that secures the power button to the palm-rest and keyboard assembly.
2. Lift the power button off the palm-rest and keyboard assembly.

## Installing the power button

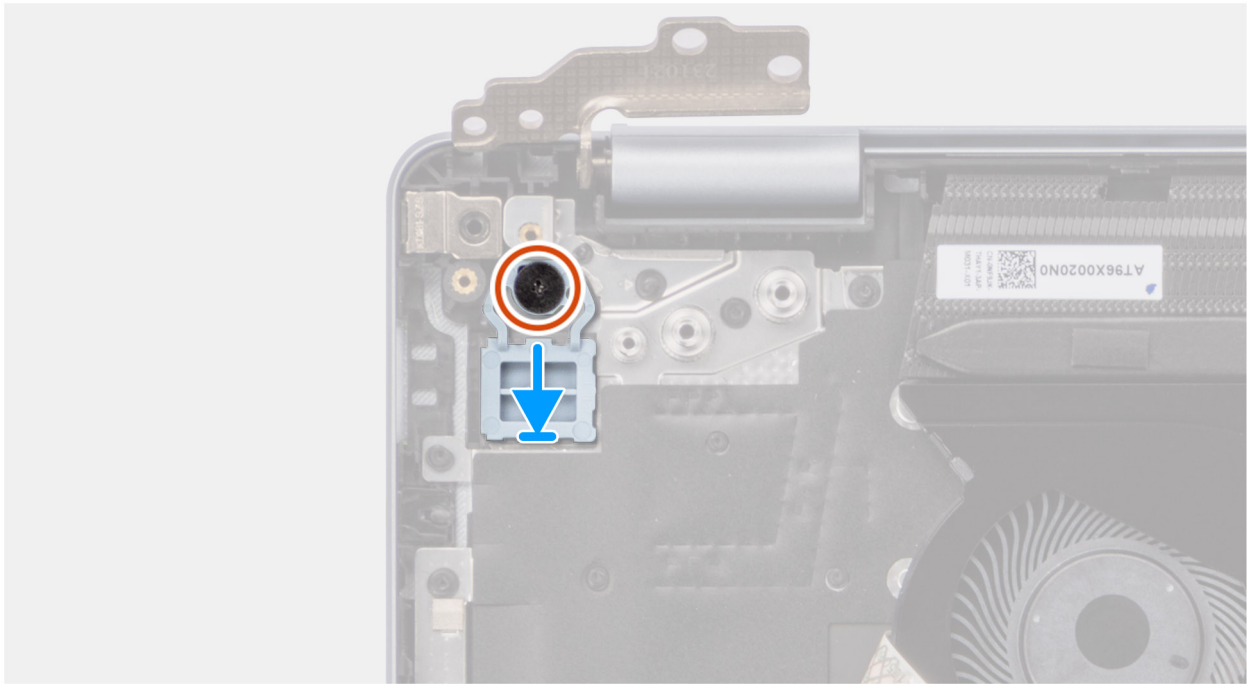
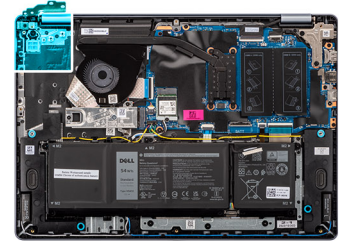
**CAUTION:** The information in this section is intended for authorized service technicians only.

### Prerequisites

If you are replacing a component, remove the existing component before performing the installation procedure.

### About this task

The following image indicates the location of the power button and provides a visual representation of the installation procedure.



**Figure 35. Installing the power button**

### Steps

1. Place the power button in the slot on the palm-rest and keyboard assembly.
2. Align the screw hole on the power button to the screw hole on the palm-rest and keyboard assembly.
3. Replace the screw (M2x2.3) that secure the power button to the palm-rest and keyboard assembly.

### Next steps

1. Install the [I/O board](#).
2. Install the [base cover](#).
3. Follow the procedure in [After working inside your computer](#).

# Power button with optional fingerprint reader

## Removing the power button with optional fingerprint reader

**CAUTION:** The information in this section is intended for authorized service technicians only.

### Prerequisites

1. Follow the procedure in [Before working inside your computer](#).
2. Remove the [base cover](#).
3. Remove the [I/O board](#).

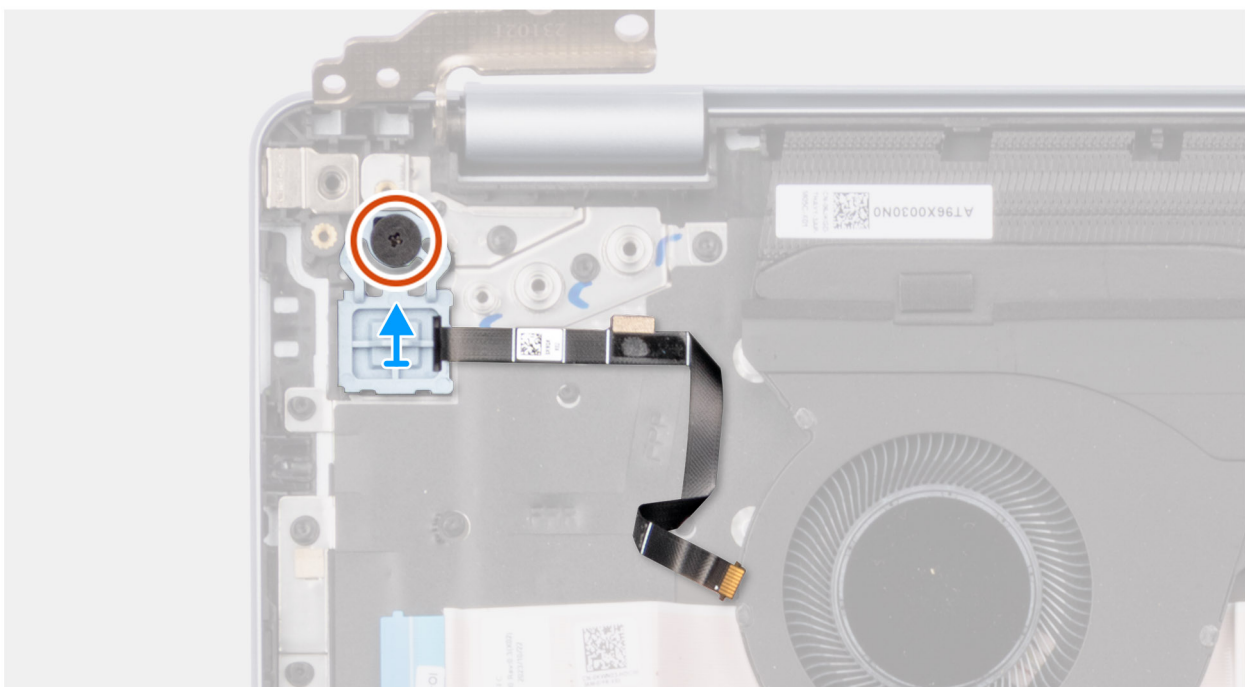
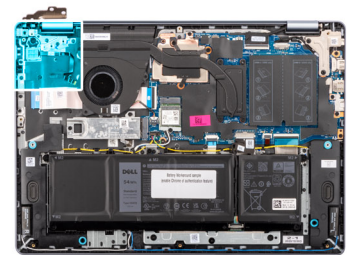
### About this task

**NOTE:** This procedure applies only to computers shipped with a power button with fingerprint reader installed.

The following image indicates the location of the power button with the optional fingerprint reader and provides a visual representation of the removal procedure.



1x  
M2x2.3



**Figure 36. Removing the power button with optional fingerprint reader**

### Steps

1. Peel the fingerprint-reader cable from the palm-rest and keyboard assembly.
2. Remove the screw (M2x2.3) that secures the power button with fingerprint-reader cable to the palm-rest and keyboard assembly.
3. Lift the power button, along with fingerprint-reader cable, off the slot on the palm-rest and keyboard assembly.

# Installing the power button with optional fingerprint reader

**CAUTION:** The information in this section is intended for authorized service technicians only.

## Prerequisites

If you are replacing a component, remove the existing component before performing the installation procedure.

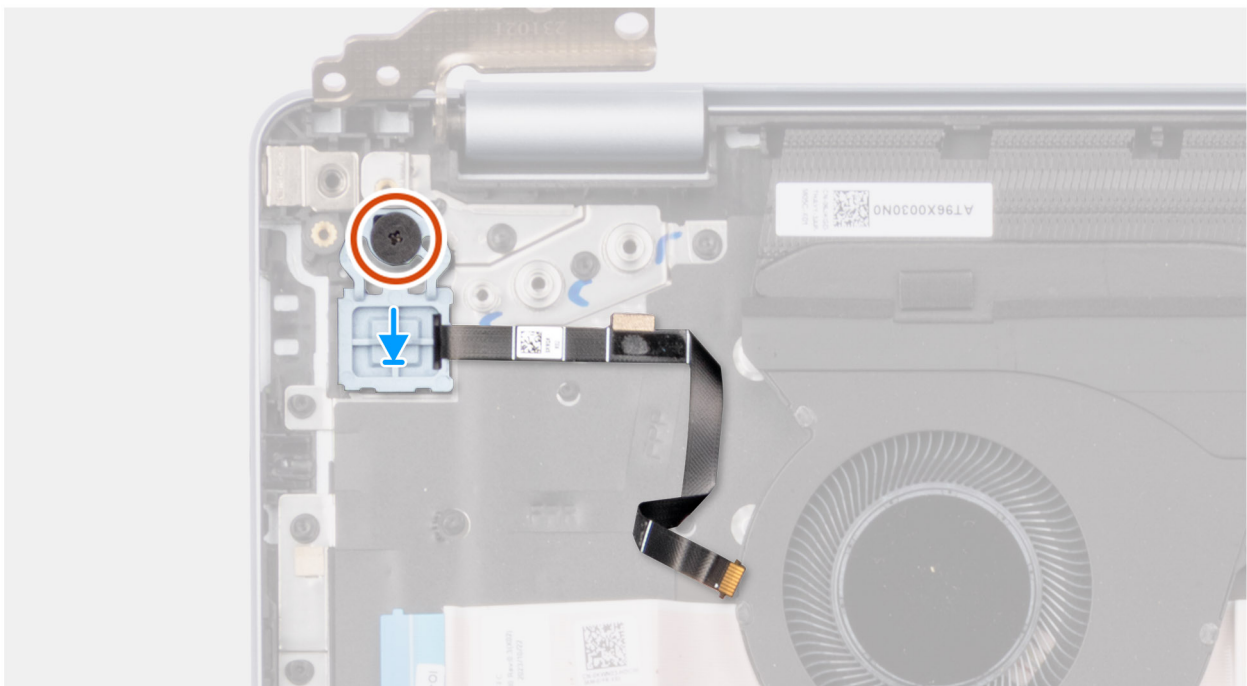
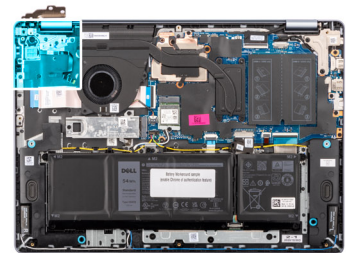
## About this task

**NOTE:** This procedure applies only to computers shipped with a power button with fingerprint reader installed.

The following image indicates the location of the power button with the optional fingerprint reader and provides a visual representation of the installation procedure.



**1x**  
M2x2.3

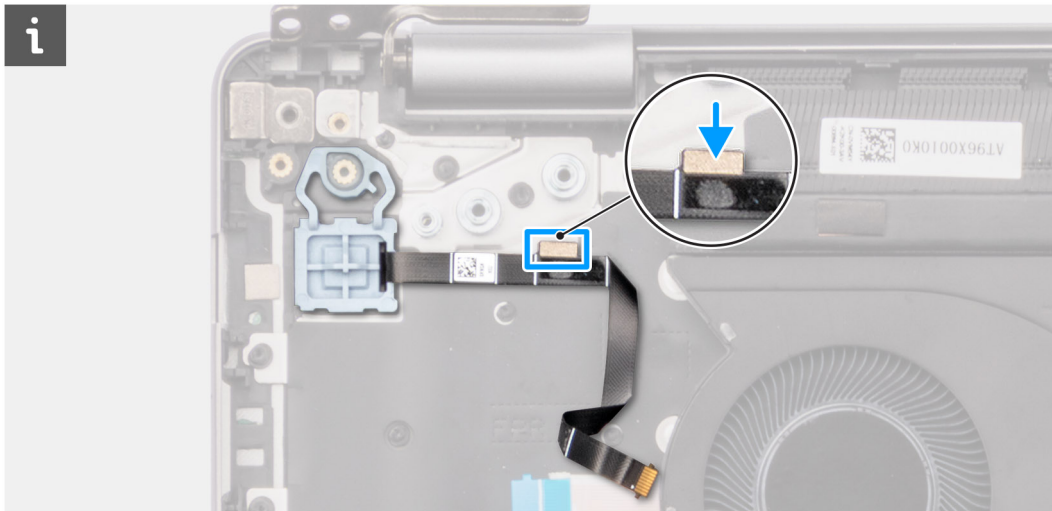


**Figure 37. Installing the power button with optional fingerprint reader**

## Steps

1. Place the power button along with fingerprint-reader cable in the slot on the palm-rest and keyboard assembly.
2. Align the screw hole on the power button to the screw hole on the palm-rest and keyboard assembly.
3. Replace the screw (M2x2.3) that secure the power button with fingerprint-reader cable to the palm-rest and keyboard assembly.
4. Adhere the fingerprint-reader cable to the palm-rest and keyboard assembly.

**NOTE:** When installing the power button, align the fingerprint reader cable to the mark at the right of the power button. The grounding tape on the top side of the cable must be adhered to the keyboard plate.



**Figure 38. Installing the power button - Grounding tape adhered to keyboard plate**

### Next steps

1. Install the [I/O board](#).
2. Install the [base cover](#).
3. Follow the procedure in [After working inside your computer](#).

## Power-adapter port

### Removing the power-adapter port

**CAUTION:** The information in this section is intended for authorized service technicians only.

#### Prerequisites

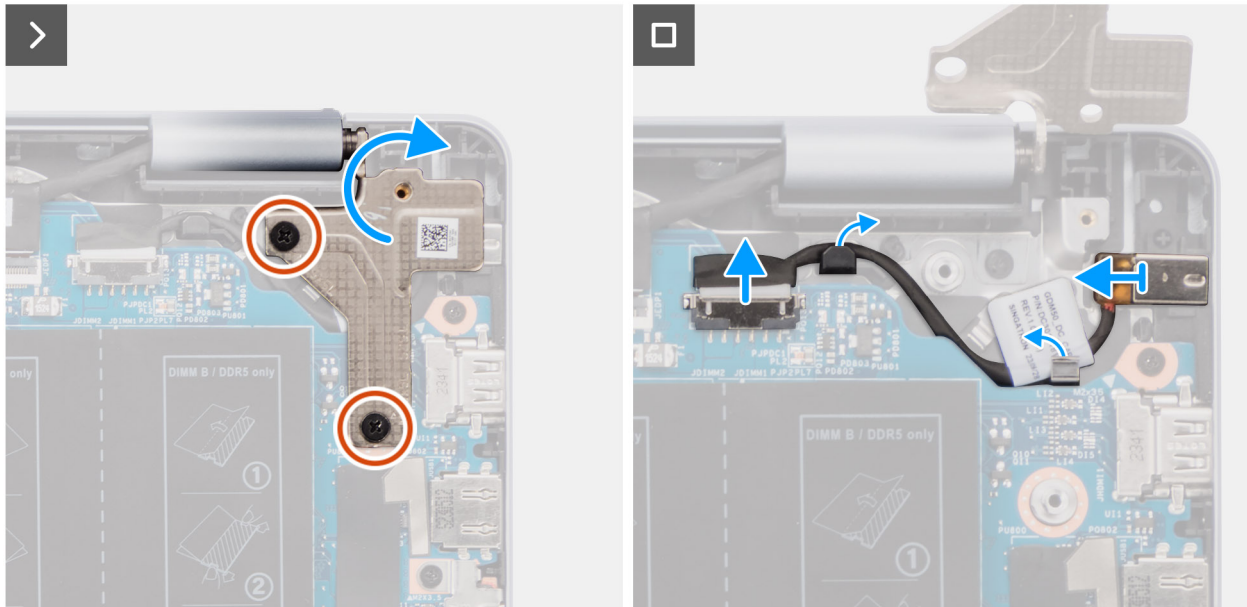
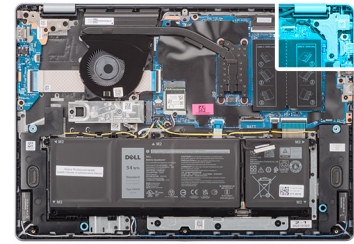
1. Follow the procedure in [Before working inside your computer](#).
2. Remove the [base cover](#).

#### About this task

The following images indicate the location of the power-adapter port and provide a visual representation of the removal procedure.



2x  
M2.5x5



**Figure 39. Removing the power-adaptor port**

### Steps

1. Remove the two screws (M2.5x5) that secure the hinge to the system board and the palm-rest and keyboard assembly.
2. Pry open the hinge away from the palm-rest and keyboard assembly to access the power-adaptor port.
3. Disconnect the power-adaptor port cable from its connector (DCIN) on the system board.
4. Remove the power-adaptor port cable through the guide on the palm-rest and keyboard assembly.
5. Remove the power-adaptor port from the slot on the palm-rest and keyboard assembly.

**NOTE:** The power-adaptor port is secured in place by the hinge. There is no screw, tape, or adhesive securing the power-adaptor port to the palm-rest. Technicians should ensure that the power-adaptor port has not fallen out when the right hinge is removed.

## Installing the power-adaptor port

**CAUTION:** The information in this section is intended for authorized service technicians only.

### Prerequisites

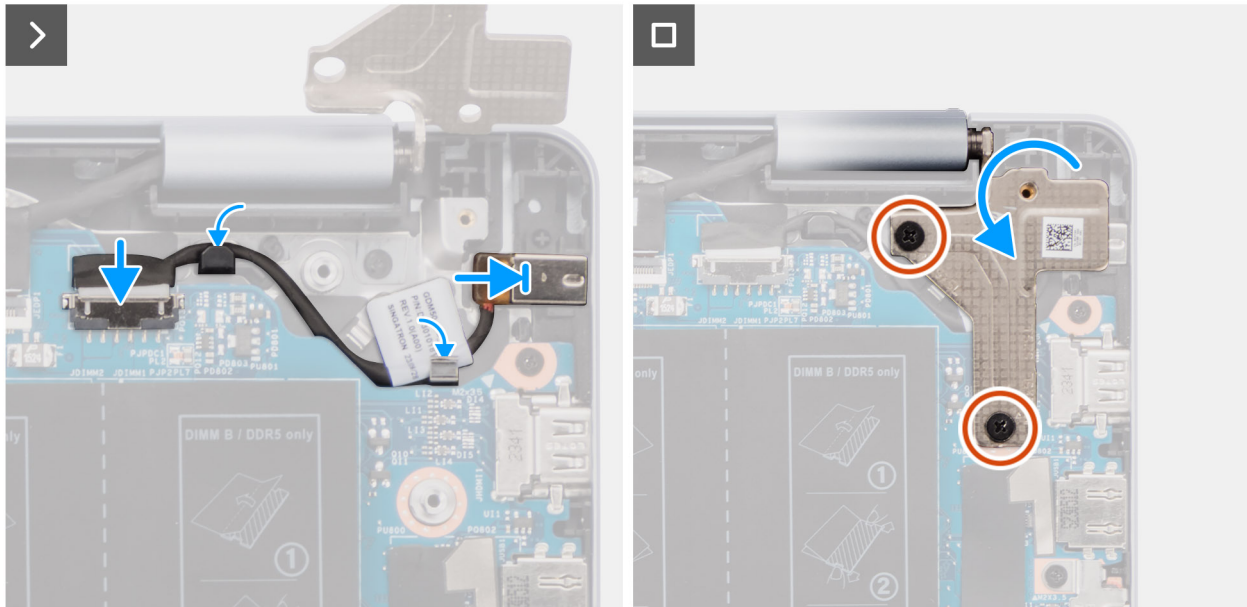
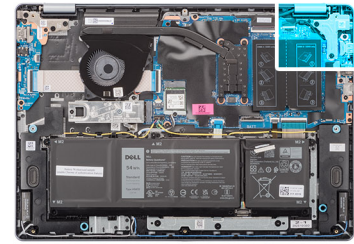
If you are replacing a component, remove the existing component before performing the installation procedure.

### About this task

The following images indicate the location of the power-adaptor port and provide a visual representation of the installation procedure.



2x  
M2.5x5



**Figure 40. Installing the power-adapter port**

### Steps

1. Align and place the power-adapter port in the slot on the palm-rest and keyboard assembly.
  - NOTE:** The power-adapter port is secured in place by the hinge. There is no screw, tape, or adhesive securing the power-adapter port to the palm-rest. Technicians should ensure that the power-adapter port has not fallen out when the right hinge is removed.
2. Route the power-adapter port cable through the guide on the palm-rest and keyboard assembly.
3. Connect the power-adapter port cable to its connector (DCIN) on the system board.
4. Press the hinge down to align the screw holes on the hinge to the screw holes on the system board and the palm-rest and keyboard assembly.
5. Replace the two screws (M2.5x5) that secure the hinge to the system board and the palm-rest and keyboard assembly.

### Next steps

1. Install the [base cover](#).
2. Follow the procedure in [After working inside your computer](#).

## System board

### Removing the system board

**CAUTION:** The information in this section is intended for authorized service technicians only.

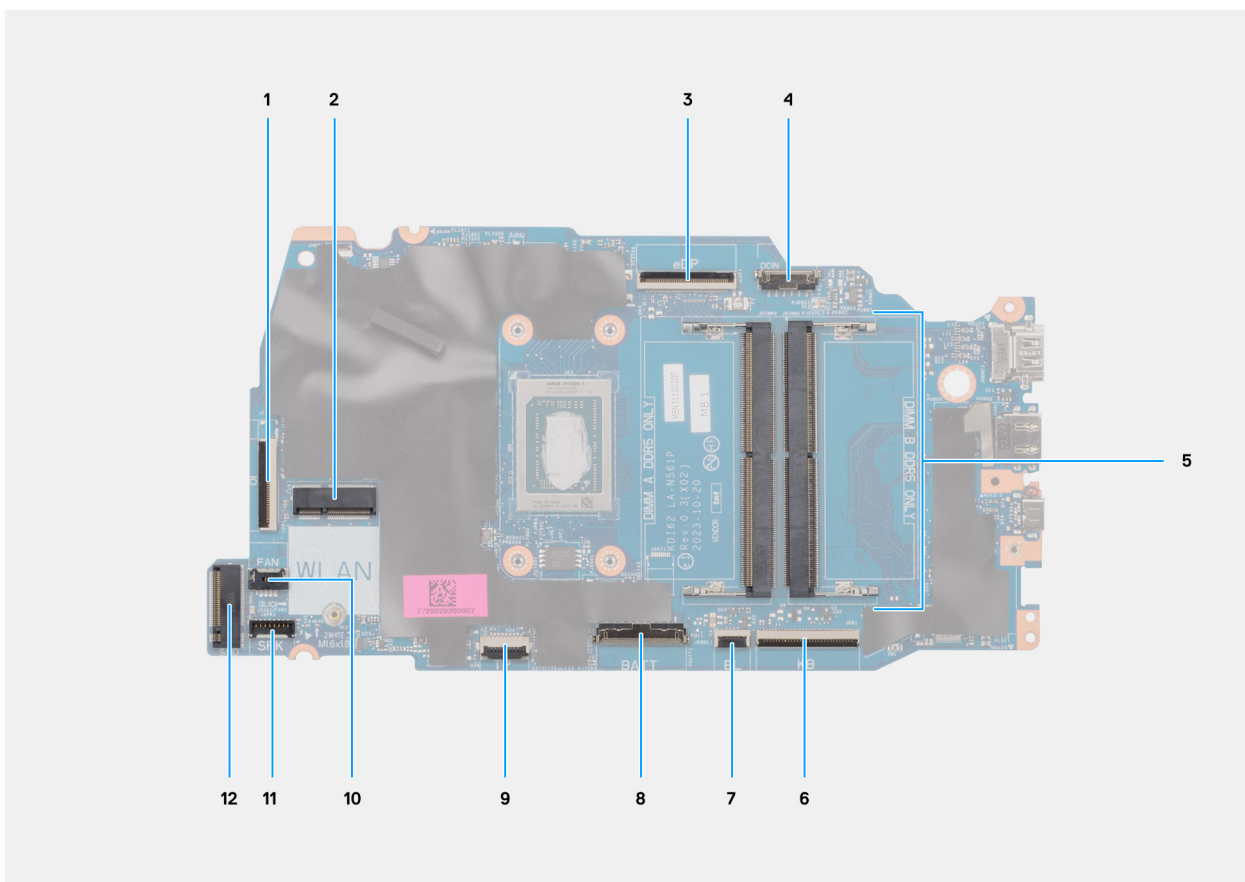
## Prerequisites

1. Follow the procedure in [Before working inside your computer](#).
2. Remove the [base cover](#).
3. Remove the [memory module](#).
4. Remove the [solid-state drive](#).
5. Remove the [wireless card](#).
6. Remove the [fan](#).
7. Remove the [heat sink](#).

**NOTE:** When removing the system board to replace/access other parts, the system board can be removed with the heat sink attached to it in order to simplify the procedure and preserve the thermal bond between the system board and heat sink.

## About this task

The following image indicates the connectors on your system board.

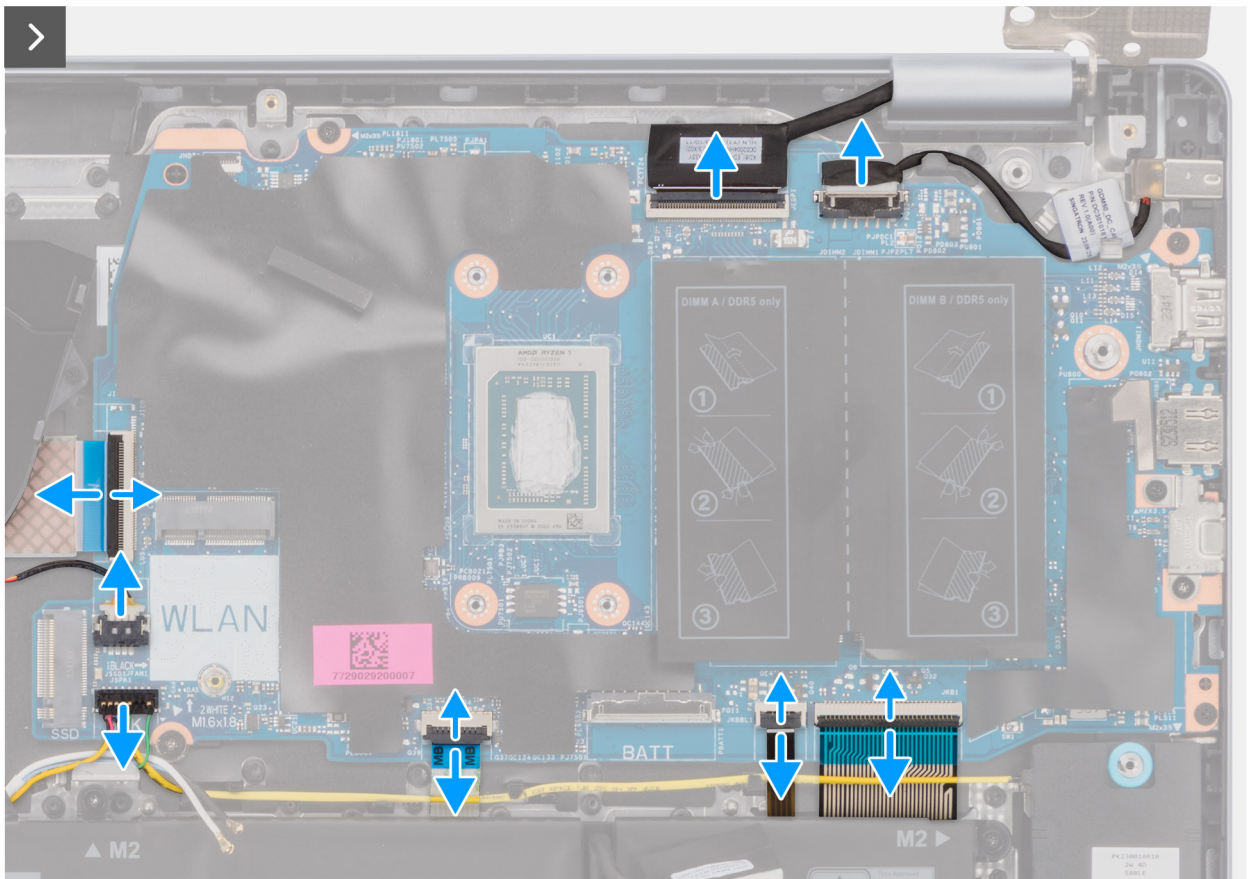
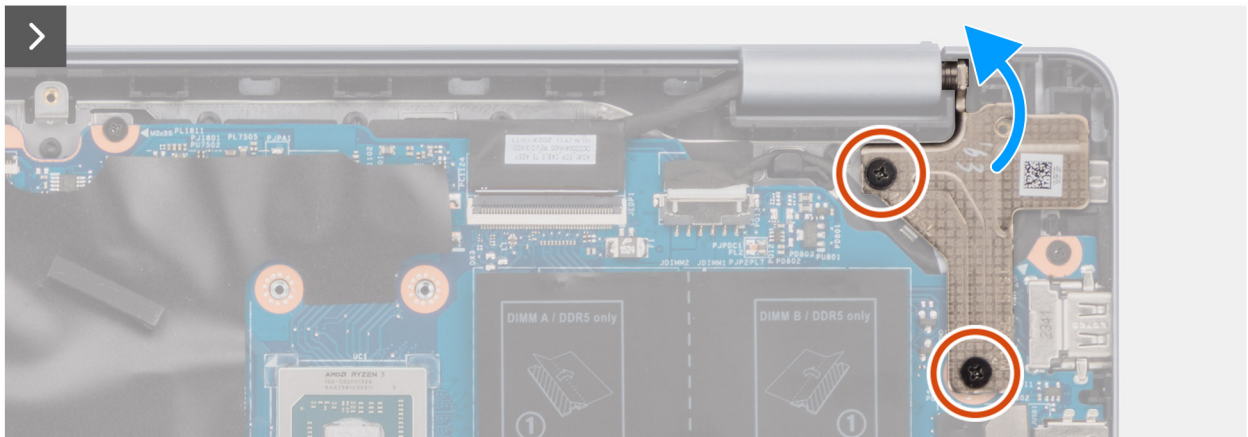
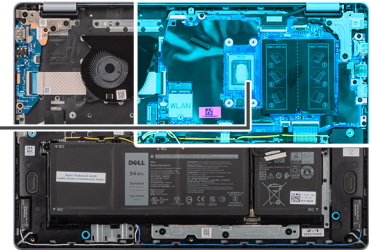


**Figure 41. System board overview**

1. I/O board cable (IO)
2. Wireless card slot (WLAN)
3. Display cable (eDP)
4. Power-adaptor port cable (DCIN)
5. Memory slots x2 (DIMM A DDR5 ONLY + DIMM B DDR5 ONLY)
6. Keyboard cable (KB)
7. Keyboard-backlight cable (BL)
8. Battery cable (BATT)
9. Touchpad cable (TP)
10. Fan cable (FAN)
11. Speaker cable (SPK)
12. Speaker cable (SPK)

## 12. M.2 solid-state drive slot (SSD)

The following images indicate the location of the system board and provide a visual representation of the removal procedure.



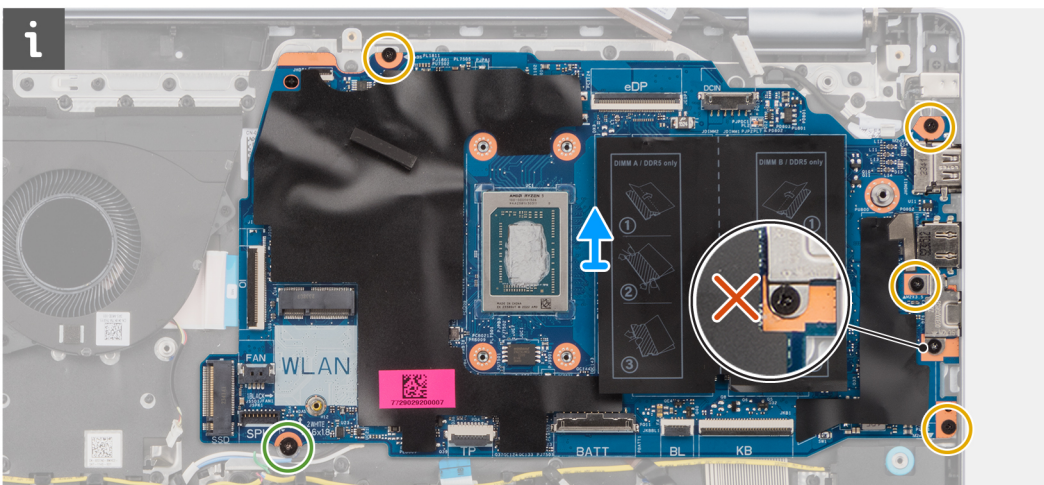


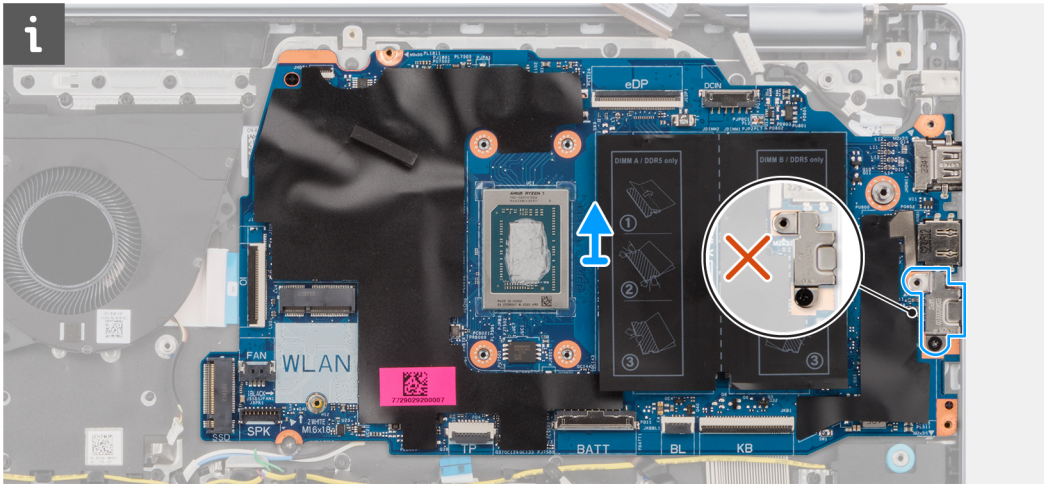
**Figure 42. Removing the system board**

**Steps**

1. Remove the two screws (M2.5x5) that secure the hinge to the palm-rest and keyboard assembly.
2. Open the display hinge at an angle of 90 degrees.
3. Disconnect the following cables on the system board:
  - a. eDP cable from its connector (eDP)
  - b. power-adaptor port cable from its connector (DCIN)
  - c. keyboard cable from its connector (KB)
  - d. keyboard-backlight cable from its connector (BL)
  - e. touchpad cable from its connector (TP)
  - f. speaker cable from its connector (SPK)
  - g. fan cable from its connector (FAN)
  - h. I/O board cable from its connector (IO)
4. Remove the screw (M1.6x1.8) that secures the system board to the palm-rest and keyboard assembly.
5. Remove the four screws (M2x3.5) that secure the system board to the palm-rest and keyboard assembly.

**i** **NOTE:** A USB Type-C bracket is secured to the system board with a single screw (M2x3.5). The bracket is bundled with the system board as a service part and **MUST NOT** be removed from the system board.





6. Carefully lift and remove the system board from the palm-rest and keyboard assembly.

## Installing the system board

**CAUTION:** The information in this section is intended for authorized service technicians only.

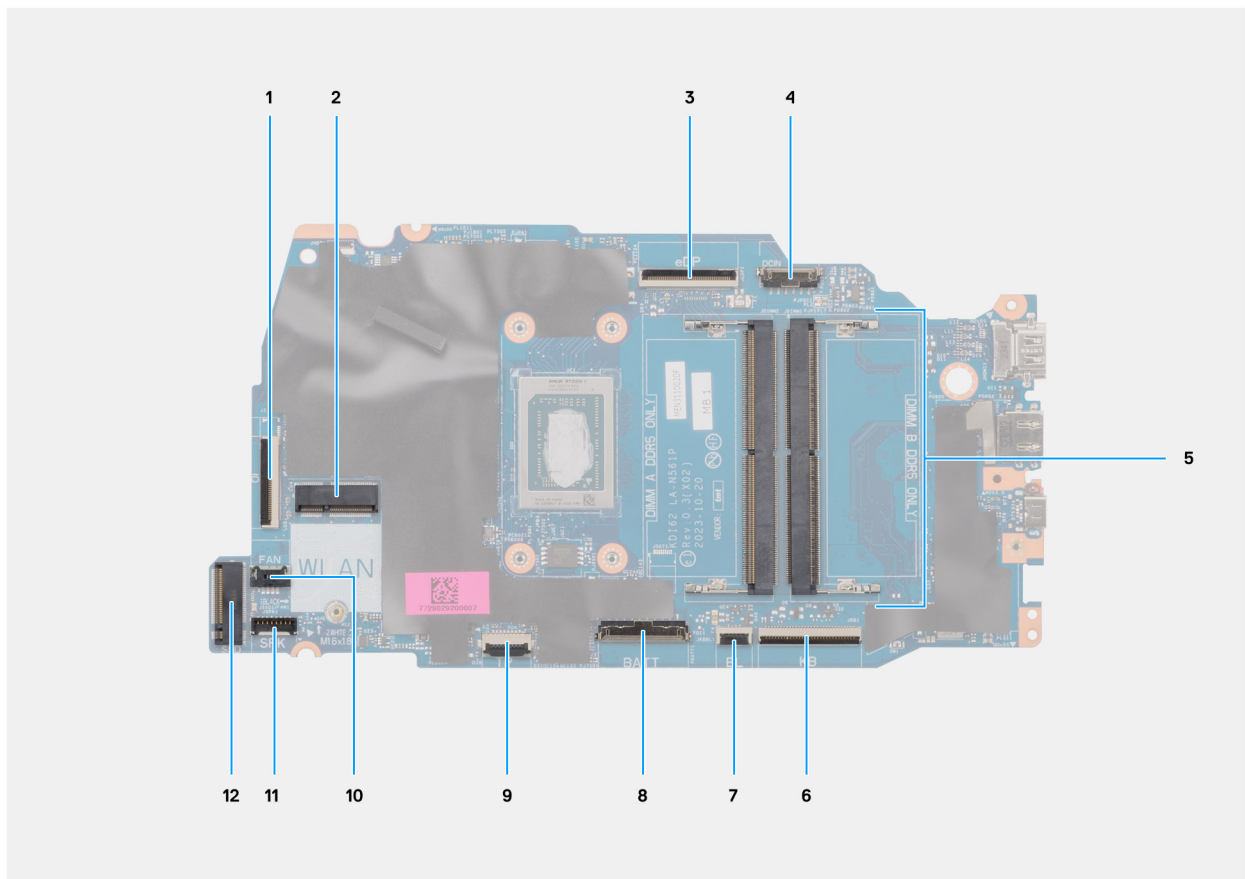
### Prerequisites

If you are replacing a component, remove the existing component before performing the installation procedure.

### About this task

**NOTE:** When installing the system board to replace/access other parts, the system board can be installed with the heat sink to it in order to simplify the procedure and preserve the thermal bond between the system board and heat sink.

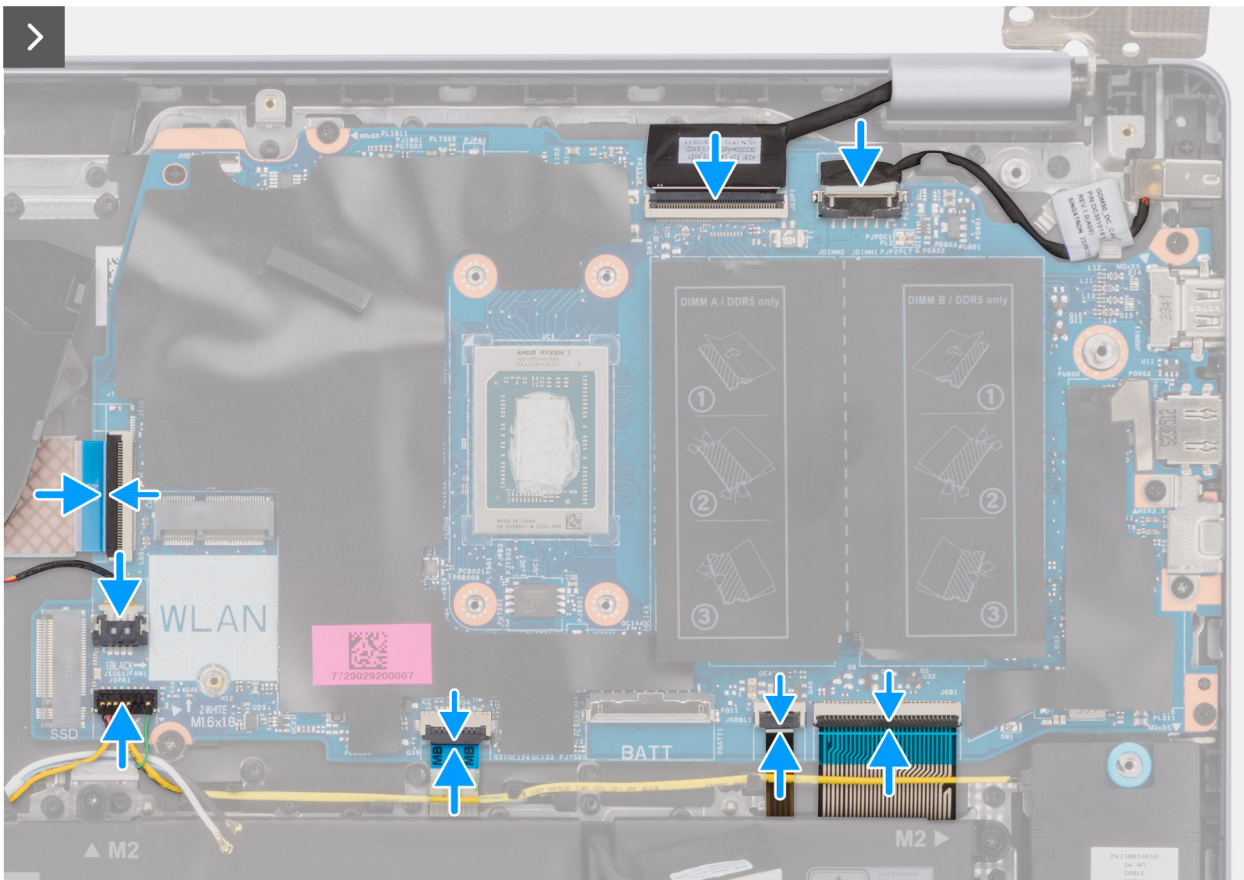
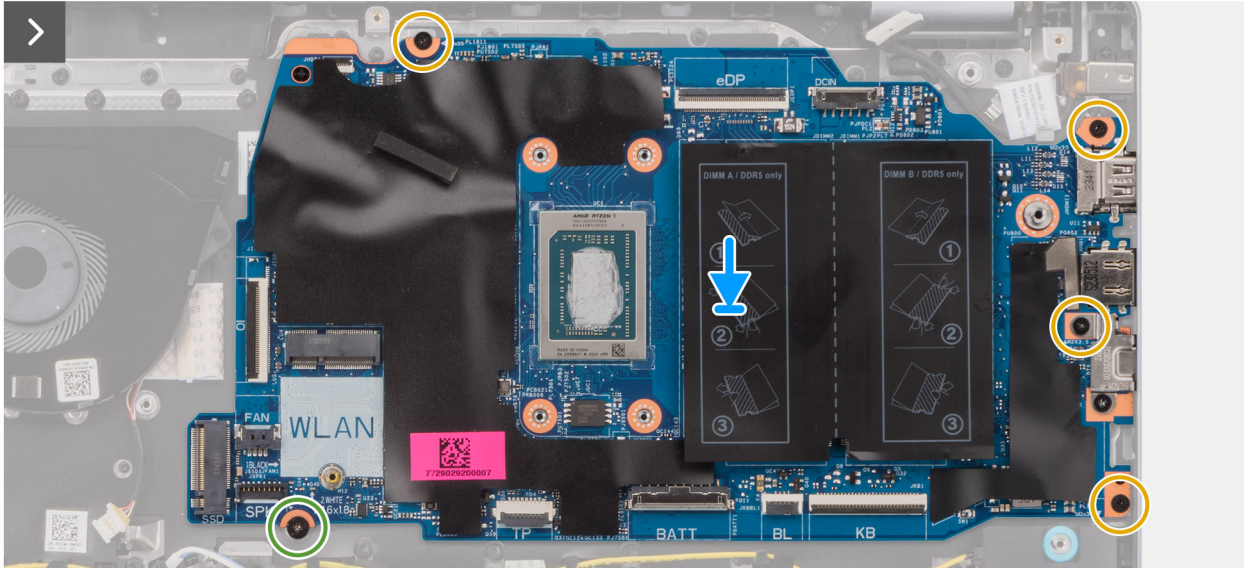
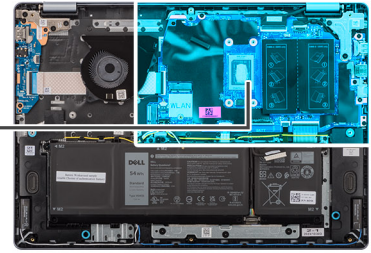
The following image indicates the connectors on your system board.

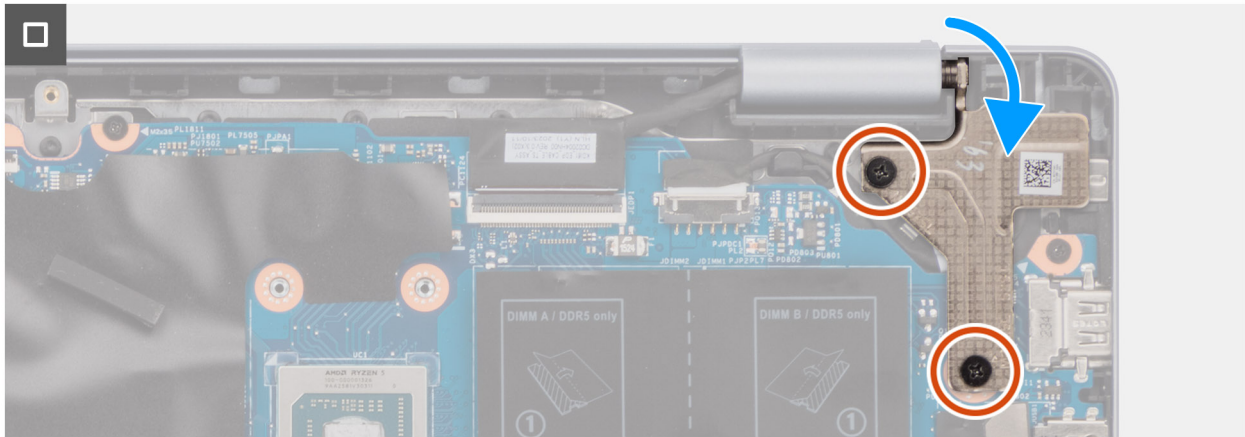


**Figure 43. System board overview**

1. I/O board cable (IO)
2. Wireless card slot (WLAN)
3. Display cable (eDP)
4. Power-adaptor port cable (DCIN)
5. Memory slots x2 (DIMM A DDR5 ONLY + DIMM B DDR5 ONLY)
6. Keyboard cable (KB)
7. Keyboard-backlight cable (BL)
8. Battery cable (BATT)
9. Touchpad cable (TP)
10. Fan cable (FAN)
11. Speaker cable (SPK)
12. M.2 solid-state drive slot (SSD)

The following images indicate the location of the system board and provide a visual representation of the installation procedure.





**Figure 44. Installing the system board**

### Steps

1. Align the ports on the system board to the port openings on the palm-rest and keyboard assembly.
2. At an angle, carefully slide and place the system board on the palm-rest and keyboard assembly.
3. Align the screw holes on the system board with the screw holes on the palm-rest and keyboard assembly.
4. Replace the screw (M1.6x1.8) that secures the system board to the palm-rest and keyboard assembly.
5. Replace the four screws (M2x3.5) that secure the system board to the palm-rest and keyboard assembly.
  - NOTE:** A USB Type-C bracket is secured to the system board with a single screw (M2x3.5). The bracket is bundled with the system board as a service part and **MUST NOT** be removed from the system board.
6. Connect the following cables to the system board:
  - a. I/O board cable to its connector (IO)
  - b. fan cable to its connector (FAN)
  - c. speaker cable to its connector (SPK)
  - d. touchpad cable to its connector (TP)
  - e. keyboard-backlight cable to its connector (BL)
  - f. keyboard cable to its connector (KB)
  - g. power-adapter port cable to its connector (DCIN)
  - h. eDP cable to its connector (eDP)
7. Close the display hinge.
8. Replace the two screws (M2.5x5) that secure the hinge to the palm-rest and keyboard assembly.

### Next steps

1. Install the [heat sink](#).
2. Install the [fan](#).
3. Install the [wireless card](#).
4. Install the [solid-state drive](#).
5. Install the [memory module](#).
6. Install the [base cover](#).
7. Follow the procedure in [After working inside your computer](#).

## Palm-rest and keyboard assembly

### Removing the palm-rest and keyboard assembly

**CAUTION:** The information in this section is intended for authorized service technicians only.

## Prerequisites

1. Follow the procedure in [Before working inside your computer](#).
2. Remove the [base cover](#).
3. Remove the [memory module](#).
4. Remove the [solid-state drive](#).
5. Remove the [wireless card](#).
6. Remove the [speakers](#).
7. Remove the [fan](#).
8. Remove the [battery](#).
9. Remove the [heat sink](#).
10. Remove the [touchpad assembly](#).
11. Remove the [I/O-board cable](#).
12. Remove the [display assembly](#).
13. Remove the [I/O board](#).
14. Remove the [power button](#) or the [power button with optional fingerprint reader](#), whichever is applicable.
15. Remove the [power-adapter port](#).
16. Remove the [system board](#).

**NOTE:** The system board can be removed with the heat sink attached to it in order to simplify the procedure and preserve the thermal bond between the system board and heat sink.

## About this task

**NOTE:** The palm-rest and keyboard assembly cannot be further disassembled. If the keyboard is malfunctioning and is required to be replaced, replace the entire palm-rest and keyboard assembly.

The image below shows the palm-rest and keyboard assembly after the pre-requisite procedures have been performed.

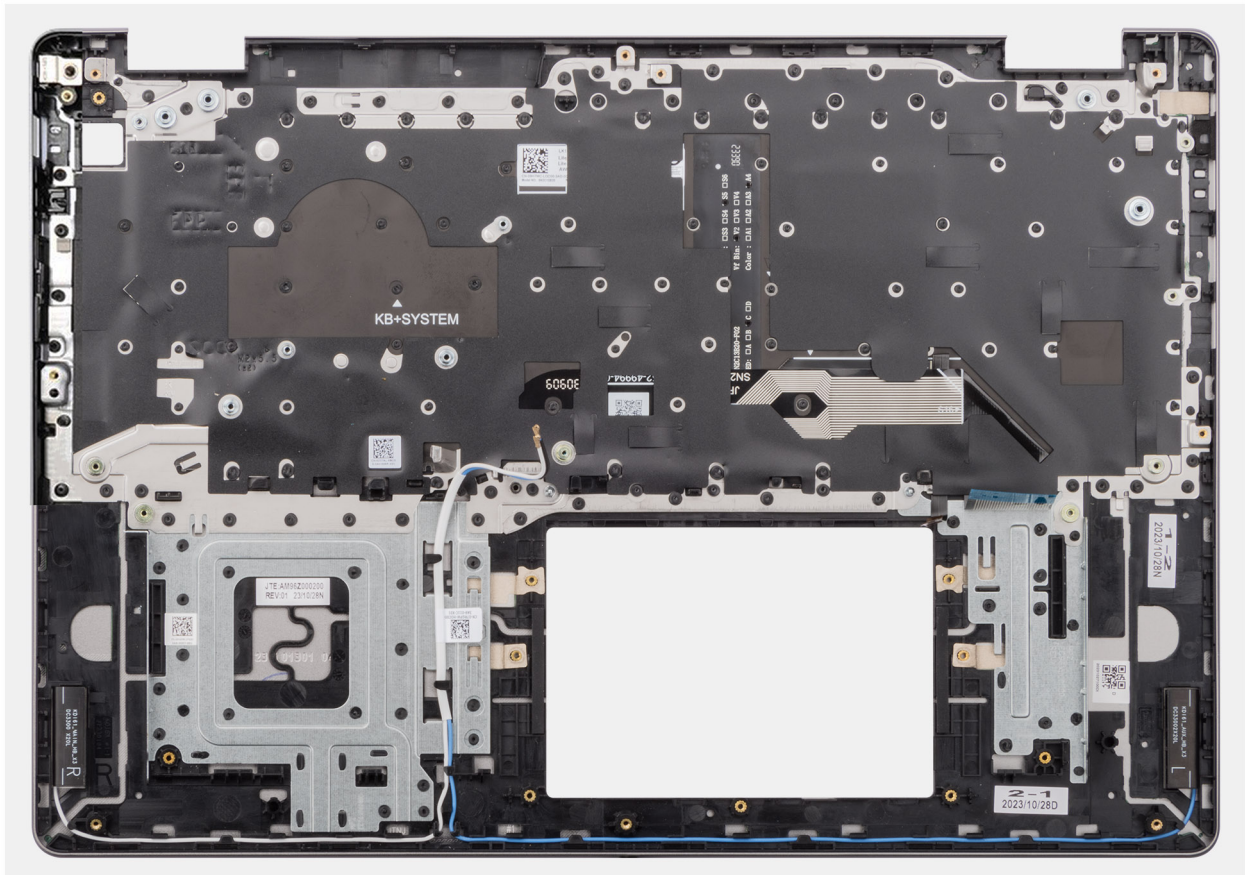


Figure 45. Removing the palm-rest and keyboard assembly

## Steps

After performing the pre-requisites, you are left with the palm-rest and keyboard assembly.

## Installing the palm-rest and keyboard assembly

**CAUTION:** The information in this section is intended for authorized service technicians only.

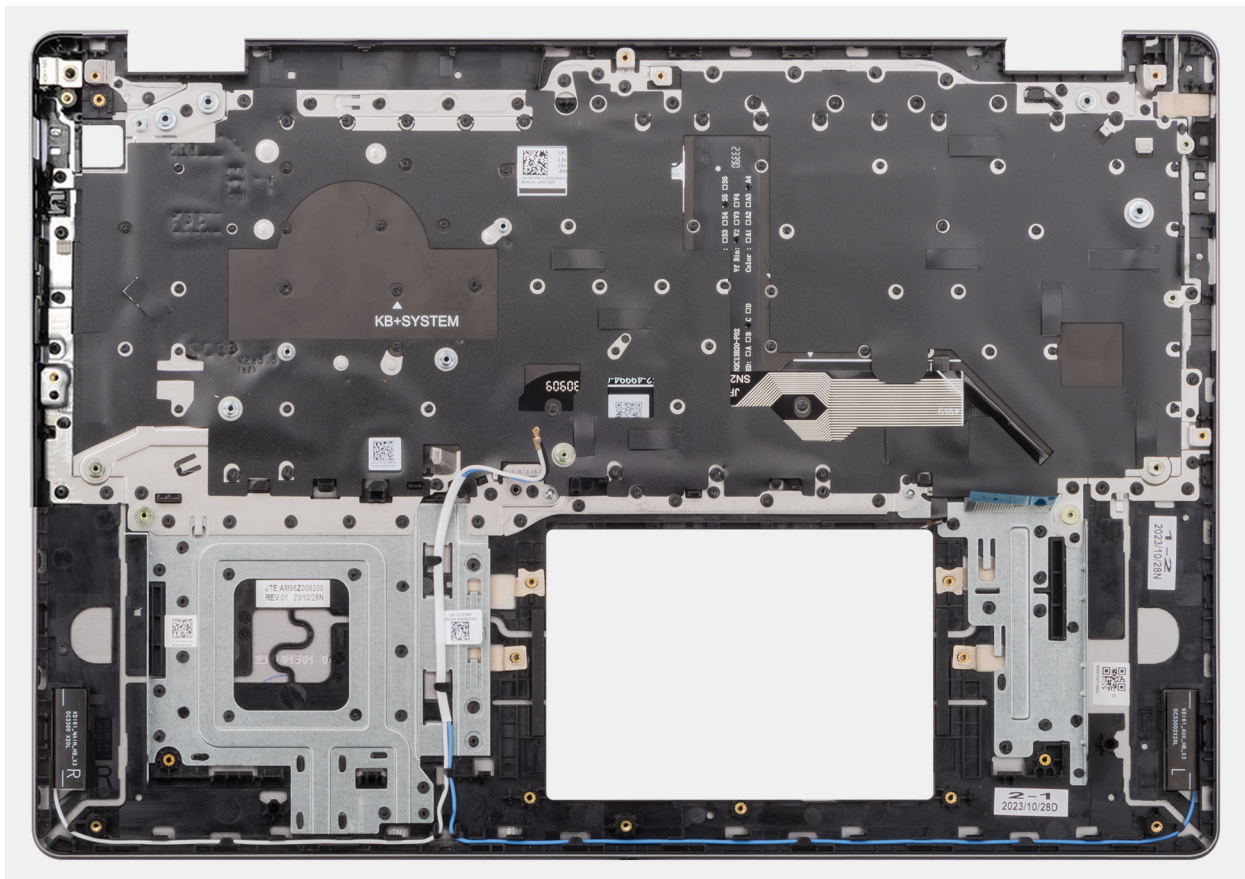
### Prerequisites

If you are replacing a component, remove the existing component before performing the installation procedure.

### About this task

**NOTE:** The system board can be installed with the heat sink attached to it in order to simplify the procedure and preserve the thermal bond between the system board and heat sink.

The following image indicates the location of the palm-rest and keyboard assembly and provides a visual representation of the installation procedure.



**Figure 46. Installing the palm-rest and keyboard assembly**

## Steps

Place the palm-rest and keyboard assembly on a flat surface and perform the following steps to install the palm-rest and keyboard assembly.

### Next steps

1. Install the [system board](#).
2. Install the [power-adaptor port](#).
3. Install the [power button](#) or the [power button with optional fingerprint reader](#), whichever is applicable.

4. Install the [I/O board](#).
5. Install the [display assembly](#).
6. Install the [I/O-board cable](#).
7. Install the [touchpad assembly](#).
8. Install the [heat sink](#).
9. Install the [battery](#).
10. Install the [fan](#).
11. Install the [speakers](#).
12. Install the [wireless card](#).
13. Install the [solid-state drive](#).
14. Install the [memory module](#).
15. Install the [base cover](#).
16. Follow the procedure in [After working inside your computer](#).

# Software

This chapter details the supported operating systems along with instructions on how to install the drivers.

## Operating system

Your Inspiron 16 5645 supports the following operating systems:

- Windows 11 Home
- Windows 11 Home National Academic
- Windows 11 Pro
- Windows 11 Pro National Academic

## Drivers and downloads

When troubleshooting, downloading, or installing drivers, it is recommended that you read the Dell Knowledge Base article Drivers and Downloads FAQs [000123347](#).

# BIOS Setup

**CAUTION:** Unless you are an expert computer user, do not change the settings in the BIOS Setup. Certain changes can make your computer work incorrectly.

**NOTE:** Depending on the computer and its installed devices, the items that are listed in this section may or may not be displayed.

**NOTE:** Before you change the settings in BIOS Setup, it is recommended that you note down the original settings for future reference.

Use BIOS Setup for the following purposes:

- Get information about the hardware installed in your computer, such as the amount of RAM and the size of the storage device.
- Change the system configuration information.
- Set or change a user-selectable option, such as the user password, type of hard drive installed, and enabling or disabling base devices.

## Entering BIOS setup program

### About this task

Turn on (or restart) your computer and press F12 immediately.

## Navigation keys

**NOTE:** For most of the System Setup options, changes that you make are recorded but do not take effect until you restart the computer.

**Table 29. Navigation keys**

Keys	Navigation
Up arrow	Moves to the previous field.
Down arrow	Moves to the next field.
Enter	Selects a value in the selected field (if applicable) or follows the link in the field.
Spacebar	Expands or collapses a drop-down list, if applicable.
Tab	Moves to the next focus area. <b>NOTE:</b> For the standard graphical user interface only.
Esc	Moves to the previous page until you view the main screen. Pressing Esc in the main screen displays a message that prompts you to save any unsaved changes and restart the computer.

## F12 One Time Boot menu

To enter the One Time Boot menu, turn on your computer, and then press F12 immediately.

**NOTE:** It is recommended to shut down the computer, if it is on.

The F12 One Time Boot menu displays the devices that you can boot from including the diagnostic option. The boot menu options are:

- Removable Drive (if available)
- STXXXX Drive (if available)

**NOTE:** XXX denotes the SATA drive number.

- Optical Drive (if available)
- SATA Hard Drive (if available)
- Diagnostics

The boot sequence screen also displays the option to access System Setup.

## System setup options

**NOTE:** Depending on your computer and its installed devices, the items that are listed in this section may or may not appear.


**Table 30. System setup options—Main menu**

<b>Main</b>	
System Time	Displays the current time in hh:mm:ss format.
System Date	Displays the current date in mm/dd/yyyy format.
BIOS Version	Displays the BIOS version.
Product Name	Displays the model number of your computer.
Service Tag	Displays the service tag of your computer.
Asset Tag	Displays the asset tag of your computer.
CPU Type	Displays the processor type.
CPU Speed	Displays the processor speed.
CPU ID	Displays the processor identification code.
<b>CPU Cache</b>	
L1 Cache	Displays the processor L1 cache size.
L2 Cache	Displays the processor L2 cache size.
L3 Cache	Displays the processor L3 cache size.
M.2 PCIe SSD	Displays the PCIe SSD information connected to the M.2 slot.
AC Adapter Type	Displays the type of AC adapter.
System Memory	Displays the size of memory installed.
Memory Speed	Displays the speed of memory.
Keyboard Type	Displays the type of keyboard installed on the computer.

**Table 31. System setup options—Advanced menu**

<b>Advanced</b>	
USB Emulation	Enables or disables the USB emulation feature. This feature defines how the BIOS, in the absence of a USB-aware operating system, handles USB devices. USB emulation is always enabled during POST.

**Table 31. System setup options—Advanced menu (continued)**

<b>Advanced</b>	
	<p> <b>NOTE:</b> You cannot boot any type of USB device (floppy, hard drive, or memory key) when this option is off.</p> <p>Default: Enabled</p>
SATA/NVMe Operation mode	<p>Allows you to configure the operating mode of the integrated SATA hard drive controller.</p> <p>Default: AHCI /NVMe</p>
Adapter Warnings	<p>Allows you to choose if the computer should display warning messages when you use AC adapters that are not supported by your computer.</p> <p>Default: Enabled</p>
Function Key Behavior	<p>Allows you to set function key or multimedia key as the default function key behavior.</p> <p>Default: Multimedia key</p>
Keyboard Illumination	<p>Selects the operating mode of the keyboard illumination feature.</p> <p>Default: Dim</p>
Keyboard Backlight with AC	<p>Selects the timeout value for the keyboard backlight when an AC adapter is plugged into the computer.</p> <p>Default: 1 minute</p>
Keyboard Backlight with Battery	<p>Selects the timeout value for the keyboard backlight when the computer is running on battery power.</p> <p>Default: 1 minute</p>
Battery Health	<p>Displays the battery health.</p>
External USB Ports	<p>Allows you to enable or disable the external USB ports.</p> <p>Default: Enabled</p>
Enable Audio	<p>Allows you to enable or disable the audio.</p> <p>Default: Enabled</p>
Microphone	<p>Allows you to enable or disable the microphone.</p> <p>Default: Enabled</p>
Camera	<p>Enables or disables the camera.</p> <p>Default: Enabled</p>
Battery Charge Configuration	<p>Set the battery charge settings with a preselected custom charge start and stop.</p> <p>Default: Adaptive</p>
Advanced Battery Charge Configuration	<p>Enable Advanced Battery Charge Configuration from the beginning of the day to a specified work period.</p> <p>Default: Disabled</p>
IPv4 HTTP Support	<p>Default: Disabled</p>
IPv6 HTTP Support	<p>Default: Disabled</p>
<b>Maintenance</b>	
Data Wipe on next boot	<p>Enables or disables data wipe on the next boot.</p>

**Table 31. System setup options—Advanced menu (continued)**

<b>Advanced</b>	
BIOS Recovery from Hard Drive	<p>Default: Disabled</p> <p>Enables the user to recover from certain corrupted BIOS conditions from a recovery file on the user primary hard drive or an external USB key.</p> <p>Default: Enabled</p>
BIOS Auto-Recovery	<p>Enables BIOS to automatically recover BIOS without user actions.</p> <p>Default: Disabled</p>
<b>SupportAssist System Resolution</b>	
Auto OS Recovery Threshold	<p>Controls the automatic boot flow for SupportAssist System Resolution Console and for the Dell OS Recovery tool.</p> <p>Default: 2</p>
SupportAssist OS Recovery	<p>Enables or disables the boot flow for the SupportAssist OS Recovery tool in the even of certain system errors.</p> <p>Default: Enabled</p>

**Table 32. System setup options—Security menu**

<b>Security</b>	
Admin Password	<p>Displays if the administrator password is clear or set.</p> <p>Default: Not Set</p>
System Password	<p>Displays if the system password is clear or set.</p> <p>Default: Not Set</p>
Admin Password	<p>Allows you to set the administrator password. The administrator password controls access to the system setup utility.</p>
System Password	<p>Allows you to set the system password. The system password controls access to the computer at boot.</p>
Password Change	<p>Allows you to permit or deny system password or HDD password changes.</p> <p>Default: Permitted</p>
Absolute®	<p>Allows you to track your computer</p> <p>Default: Enabled</p>
Absolute® Status	<p>Allows you to activate or deactivate the Absolute® feature</p> <p>Displays if the system password is clear or set.</p> <p>Default: Deactivate</p>
WINDOWS SMM SECURITY MITIGATIONS TABLE (WSMT)	<p>Enables or disables configuration of platform features on Dell Client Systems with WSMT-enabled BIOS.</p> <p>Default: Enabled</p>
Firmware TPM	<p>Enable or disable the firmware TPM.</p> <p>Default: Disabled</p>
PPI Bypass for Clear Command	<p>Allows you to control the TPM Physical Presence Interface (PPI). When enabled, this setting will allow the OS to skip</p>

**Table 32. System setup options—Security menu (continued)**

<b>Security</b>	
	<p>BIOS PPI user prompts when issuing the Clear command. Changes to this setting take effect immediately.</p> <p>Default: Disabled</p>
<b>TPM Security</b>	<p>TPM 2.0 Security options.</p>
TPM On	<p>Enable or disable the TPM Security options.</p> <p>Default: On</p>
PPI Bypass for Enable Commands	<p>Controls the TPM Physical Presence Interface(PPI). When enabled, this setting allows the OS to skip BIOS PPI user prompts when issuing TPM PPI enable and activate commands.</p> <p>Default: Disabled</p>
PPI Bypass for Disable Commands	<p>Controls the TPM Physical Presence Interface(PPI). When enabled, this setting will allow the OS to skip BIOS PPI user prompts when issuing TPM PPI disable and deactivate commands(#2, 4, 7, 9, &amp; 11).</p> <p>Default: Disabled</p>
Attestation Enable	<p>Allows the user to control whether the TPM Endorsement Hierarchy is available to the OS.</p> <p>Default: Enabled</p>
Key Storage Enable	<p>Allows the user to control whether TPM Storage Hierarchy is available to the operating system.</p> <p>Default: Enabled</p>
SHA-256	<p>Enables the BIOS and the TPM to use the SHA-256 hash algorithm to extend measurements into the TPM PCRs during BIOS boot.</p> <p>Default: Enabled</p>
Clear	<p>Clears the TPM owner information, and returns the TPM to the default state.</p> <p>Default: Disabled</p>
PPI Bypass for Clear Commands	<p>Controls the TPM Physical Presence Interface(PPI). When enabled, this setting will allow the OS to skip BIOS PPI user prompts when issuing the Clear command.</p> <p>Default: Disabled</p>
TPM State	<p>Displays the state of the TPM Module on the computer.</p> <p>Default: Enabled</p>
Enable Pre-Boot DMA support	<p>Enable or disable the pre-boot DMA support.</p> <p>Default: Enabled</p>
Enable OS kernel DMA support	<p>Enable or disable the OS kernel DMA support.</p> <p>Default: Enabled</p>
<b>Secure Boot</b>	
System Status:	
Secure Boot Database	<p>A security standard that ensures the device boots using only software that is trusted by the Original Equipment Manufacturer (OEM)</p>

**Table 32. System setup options—Security menu (continued)**

<b>Security</b>	
Secure Boot Status	<p>Default: Installed and Locked</p> <p>Ensure that only trusted software can be executed on the system.</p>
Secure Boot Mode	<p>Default: Disabled</p> <p>Prevents any malicious software from loading when computer starts up.</p> <p>Default: Deployed Mode</p>
User Customized Security	<p>Default: No</p>
Secure Boot	<p>Enables or disables Secure Boot.</p> <p>Default: Disabled</p>
Select Secure Mode	<p>Default: Deployed Mode</p>
<b>Expert Key Management</b>	
Custom Mode	<p>Allows you to manipulate the security key databases only if the system is in Custom Mode.</p> <p>Default: Disabled</p> <p>The options are:</p> <ul style="list-style-type: none"> <li>● PK (default)</li> <li>● KEK</li> <li>● db</li> <li>● dbx</li> </ul> <p>If you enable the Custom Mode , the relevant options for PK, KEK, db, and dbx appear.</p> <p>The options are:</p> <ul style="list-style-type: none"> <li>● Save to File- Saves the key to a user-selected file</li> <li>● Replace from File- Replaces the current key with a key from a user-selected file</li> <li>● Append from File- Adds a key to the current database from a user-selected file</li> <li>● Delete- Deletes the selected key</li> <li>● Reset All Keys- Resets to default setting</li> <li>● Delete All Keys- Deletes all the keys</li> </ul>
Enable Microsoft UEFI CA	<p>Enables UEFI CA to be included in the BIOS UEFI Secure Boot DB.</p> <p>Default: Disabled</p>

**Table 33. System setup options—Boot menu**

<b>Boot</b>	
File Browser Add Boot Option	Allows you to add boot options.
UEFI Boot	Displays the location where UEFI bootable file is located.

**Table 34. System setup options—Exit menu**

<b>Exit</b>	
Exit Saving Changes	Allows you to exit system setup and save your changes.
Save Change Without Exit	Allows you to save your changes without exiting the BIOS setup.


**Table 34. System setup options—Exit menu (continued)**

Exit	
Exit Discarding Changes	Allows you to exit the BIOS setup without saving the changes.
Load Optimal Defaults	Allows you to restore default values for all system setup options.
Discard Changes	Allows you to load previous values for all system setup options.

## Updating the BIOS

### Updating the BIOS in Windows

#### Steps

1. Go to [Dell Support Site](#).
2. Click **Product support**. In the **Search support** box, enter the Service Tag of your computer, and then click **Search**.  
 **NOTE:** If you do not have the Service Tag, use the SupportAssist feature to automatically identify your computer. You can also use the product ID or manually browse for your computer model.
3. Click **Drivers & Downloads**. Expand **Find drivers**.
4. Select the operating system installed on your computer.
5. In the **Category** drop-down list, select **BIOS**.
6. Select the latest version of BIOS, and click **Download** to download the BIOS file for your computer.
7. After the download is complete, browse the folder where you saved the BIOS update file.
8. Double-click the BIOS update file icon and follow the on-screen instructions.  
For more information about how to update the system BIOS, search in the Knowledge Base Resource at [Dell Support Site](#).

### Updating the BIOS using the USB drive in Windows

#### Steps

1. Follow the procedure from step 1 to step 6 in [Updating the BIOS in Windows](#) to download the latest BIOS Setup program file.
2. Create a bootable USB drive. For more information, search the Knowledge Base Resource at [Dell Support Site](#).
3. Copy the BIOS Setup program file to the bootable USB drive.
4. Connect the bootable USB drive to the computer that needs the BIOS update.
5. Restart the computer and press **F12**.
6. Select the USB drive from the **One Time Boot Menu**.
7. Type the BIOS Setup program filename and press **Enter**.  
The **BIOS Update Utility** appears.
8. Follow the on-screen instructions to complete the BIOS update.

### Updating the BIOS from the F12 One Time Boot menu


Update your computer BIOS using the BIOS update.exe file that is copied to a FAT32 USB drive and booting from the F12 **One Time Boot** menu.

#### About this task

##### BIOS Update

You can run the BIOS update file from Windows using a bootable USB drive or you can also update the BIOS from the F12 **One Time Boot** menu on the computer.

Most of the Dell computers built after 2012 have this capability, and you can confirm by booting your computer to the F12 **One Time Boot** Menu to see if BIOS FLASH UPDATE is listed as a boot option for your computer. If the option is listed, then the BIOS supports this BIOS update option.


 **NOTE:** Only computers with the BIOS Flash Update option in the F12 **One Time Boot** menu can use this function.

### Updating from the One Time Boot menu

To update your BIOS from the F12 **One Time Boot** menu, you need the following:

- USB drive formatted to the FAT32 file system (key does not have to be bootable)
- BIOS executable file that you downloaded from the Dell Support website and copied to the root of the USB drive
- AC power adapter that is connected to the computer
- Functional computer battery to flash the BIOS

Perform the following steps to perform the BIOS update flash process from the F12 menu:

 **CAUTION:** Do not turn off the computer during the BIOS update process. The computer may not boot if you turn off your computer.

### Steps

1. From a turn off state, insert the USB drive where you copied the flash into a USB port of the computer.
2. Turn on the computer and press F12 to access the **One Time Boot** Menu, select BIOS Update using the mouse or arrow keys then press Enter.  
The flash BIOS menu is displayed.
3. Click **Flash from file**.
4. Select an external USB device.
5. Select the file and double-click the flash target file, and then click **Submit**.
6. Click **Update BIOS**. The computer restarts to flash the BIOS.
7. The computer will restart after the BIOS update is completed.

## System and setup password


Table 35. System and setup password

Password type	Description
System password	Password that you must enter to log in to your system.
Setup password	Password that you must enter to access and make changes to the BIOS settings of your computer.

You can create a system password and a setup password to secure your computer.

 **CAUTION:** The password features provide a basic level of security for the data on your computer.

 **CAUTION:** Anyone can access the data that is stored on your computer, when not locked and left unattended.

 **NOTE:** System and setup password feature is disabled.

## Assigning a System Setup password

### Prerequisites

You can assign a new System or Admin Password only when the status is in **Not Set**.

### About this task

To enter BIOS System Setup, press F2 immediately after a power-on or reboot.

### Steps

1. In the **System BIOS** or **System Setup** screen, select **Security** and press Enter.  
The **Security** screen is visible.
2. Select **System/Admin Password** and create a password in the **Enter the new password** field.  
Use the following guidelines to assign the system password:
  - A password can have up to 32 characters.
  - At least one special character: "( ! " # \$ % & ' \* + , - . / : ; < = > ? @ [ \ ] ^ \_ ` { | } )"
  - Numbers 0 to 9.
  - Upper case letters from A to Z.
  - Lower case letters from a to z.
3. Type the system password that you entered earlier in the **Confirm new password** field and click **OK**.
4. Press Esc and save the changes as prompted by the message.
5. Press Y to save the changes.  
The computer restarts.

## Deleting or changing an existing system setup password


### Prerequisites

Ensure that the **Password Status** is Unlocked (in the System Setup) before attempting to delete or change the existing System and/or Setup password. You cannot delete or change an existing System or Setup password, if the **Password Status** is Locked.

### About this task

To enter the System Setup, press F2 immediately after a power-on or reboot.


### Steps

1. In the **System BIOS** or **System Setup** screen, select **System Security** and press Enter.  
The **System Security** screen is displayed.
2. In the **System Security** screen, verify that the Password Status is **Unlocked**.
3. Select **System Password**, update, or delete the existing system password, and press Enter or Tab.
4. Select **Setup Password**, update, or delete the existing setup password, and press Enter or Tab.  
 **NOTE:** If you change the System and/or Setup password, reenter the new password when prompted. If you delete the System and/or Setup password, confirm the deletion when prompted.
5. Press Esc. A message prompts you to save the changes.
6. Press Y to save the changes and exit from System Setup.  
The computer restarts.

## Clearing BIOS (System Setup) and System passwords

### About this task

To clear the computer or BIOS passwords, contact Dell technical support as described at [Contact Support](#). For more information, go to [Dell Support Site](#).

-  **NOTE:** For information about how to reset Windows or application passwords, see the documentation accompanying Windows or your application.

# Troubleshooting

## Handling swollen rechargeable Li-ion batteries

Like most laptops, Dell laptops use Lithium-ion batteries. One type of Lithium-ion battery is the rechargeable Li-ion battery. Rechargeable Li-ion batteries have increased in popularity in recent years and have become standard in the electronics industry due to customer preferences for a slim form factor (especially with newer ultra-thin laptops) and long battery life. Inherent to rechargeable Li-ion battery technology is the potential for swelling of the battery cells.

A swollen battery may impact the performance of the laptop. To prevent possible further damage to the device enclosure or internal components leading to malfunction, discontinue the use of the laptop and discharge it by disconnecting the AC adapter and letting the battery drain.

Swollen batteries should not be used and should be replaced and disposed of properly. We recommend contacting Dell product support for options to replace a swollen battery under the terms of the applicable warranty or service contract, including options for replacement by a Dell authorized service technician.

The guidelines for handling and replacing rechargeable Li-ion batteries are as follows:

- Exercise caution when handling rechargeable Li-ion batteries.
- Discharge the battery before removing it from the system. To discharge the battery, unplug the AC adapter from the system and operate the system only on battery power. When the system will no longer turn on when the power button is pressed, the battery is fully discharged.
- Do not crush, drop, mutilate, or penetrate the battery with foreign objects.
- Do not expose the battery to high temperatures, or disassemble battery packs and cells.
- Do not apply pressure to the surface of the battery.
- Do not bend the battery.
- Do not use tools of any type to pry on or against the battery.
- If a battery gets stuck in a device as a result of swelling, do not try to free it as puncturing, bending, or crushing a battery can be dangerous.
- Do not attempt to reassemble a damaged or swollen battery into a laptop.
- Swollen batteries that are covered under warranty should be returned to Dell in an approved shipping container (provided by Dell)—this is to comply with transportation regulations. Swollen batteries that are not covered under warranty should be disposed of at an approved recycling center. Contact Dell product support at [Dell Support Site](#) for assistance and further instructions.
- Using a non-Dell or incompatible battery may increase the risk of fire or explosion. Replace the battery only with a compatible battery purchased from Dell that is designed to work with your Dell computer. Do not use a battery from other computers with your computer. Always purchase genuine batteries from [Dell Site](#) or otherwise directly from Dell.

Rechargeable Li-ion batteries can swell for various reasons such as age, number of charge cycles, or exposure to high heat. For more information about how to improve the performance and lifespan of the laptop battery and to minimize the possibility of occurrence of the issue, search Dell Laptop Battery in the Knowledge Base Resource at [Dell Support Site](#).

## Locate the Service Tag or Express Service Code of your Dell computer

Your Dell computer is uniquely identified with a Service Tag or Express Service Code. To view relevant support resources for your Dell computer, we recommend entering the Service Tag or Express Service Code at [Dell Support Site](#).


For more information about how to find the Service Tag for your computer, see [Instructions on how to find your Service Tag or Serial Number](#).

# Dell SupportAssist Pre-boot System Performance Check diagnostics

## About this task

SupportAssist diagnostics (also known as system diagnostics) performs a complete check of your hardware. The Dell SupportAssist Pre-boot System Performance Check diagnostics is embedded with the BIOS and launched by the BIOS internally. The embedded system diagnostics provides options for particular devices or device groups allowing you to:

- Run tests automatically or in an interactive mode.
- Repeat the tests.
- Display or save test results.
- Run thorough tests to introduce additional test options to provide extra information about one or more failed devices.
- View status messages that inform you the tests are completed successfully.
- View error messages that inform you of problems encountered during testing.

 **NOTE:** Some tests for specific devices require user interaction. Always ensure that you are present at the computer terminal when the diagnostic tests are performed.

For more information, see the knowledge base article [000180971](#).

## Running the SupportAssist Pre-Boot System Performance Check


### Steps

1. Turn on your computer.
2. As the computer boots, press the F12 key as the Dell logo appears.
3. On the boot menu screen, select the **Diagnostics** option.
4. Click the arrow at the bottom left corner.  
Diagnostics front page is displayed.
5. Click the arrow in the lower-right corner to go to the page listing.  
The items that are detected are listed.
6. To run a diagnostic test on a specific device, press Esc and click **Yes** to stop the diagnostic test.
7. Select the device from the left pane and click **Run Tests**.
8. If there are any issues, error codes are displayed.  
Note the error code and validation number and contact Dell.


## Built-in self-test (BIST)

### M-BIST

M-BIST (Built In Self-Test) is the system board built-in self-test diagnostics tool that improves the diagnostics accuracy of system board Embedded Controller (EC) failures.

 **NOTE:** M-BIST can be manually initiated before Power On Self-Test (POST).

### How to run M-BIST

 **NOTE:** M-BIST must be initiated on the computer from a power-off state that is either connected to AC power or with a battery only.

1. Press and hold both the **M** key on the keyboard and the **power button** to initiate M-BIST.
2. The battery indicator LED may exhibit two states:
  - a. OFF: No fault was detected with the system board.
  - b. AMBER: Amber indicates a problem with the system board.

- If there is a failure with the system board, the battery status LED flashes one of the following error codes for 30 seconds:

**Table 36. LED error codes**

Blinking Pattern		Possible Problem
Amber	White	
2	1	CPU Failure
2	8	LCD Power Rail Failure
1	1	TPM Detection Failure
2	4	Memory/RAM failure

- If there is no failure with the system board, the LCD cycles through the solid color screens that are described in the LCD-BIST section for 30 seconds and then turn off.

## LCD Power rail test (L-BIST)

L-BIST is an enhancement to the single LED error code diagnostics and is automatically initiated during POST. L-BIST will check the LCD power rail. If there is no power being supplied to the LCD (that is if the L-BIST circuit fails), the battery status LED flashes either an error code [2,8] or an error code [2,7].

**NOTE:** If L-BIST fails, LCD-BIST cannot function as no power will be supplied to the LCD.

### How to invoke the L-BIST Test

- Press the power button to start the computer.
- If the computer does not start up normally, look at the battery status LED:
  - If the battery status LED flashes an error code [2,7], the display cable may not be connected properly.
  - If the battery status LED flashes an error code [2,8], there is a failure on the LCD power rail of the system board, hence there is no power that is supplied to the LCD.
- For cases, when a [2,7] error code is shown, check to see if the display cable is properly connected.
- For cases when a [2,8] error code is shown, replace the system board.

## LCD Built-in Self-Test (BIST)

Dell laptops have a built-in diagnostic tool that helps you determine if the screen abnormality you are experiencing is an inherent problem with the LCD (screen) of the Dell laptop or with the video card (GPU) and computer settings.

When you notice screen abnormalities like flickering, distortion, clarity issues, fuzzy or blurry image, horizontal or vertical lines, color fade and so on, it is always a good practice to isolate the LCD (screen) by running the Built-In Self-Test (BIST).

### How to invoke the LCD BIST Test

- Power off the Dell laptop.
- Disconnect any peripherals that are connected to the laptop. Connect only the AC adapter (charger) to the laptop.
- Ensure that the LCD (screen) is clean (no dust particles on the surface of the screen).
- Press and hold the **D** key and **Power on** the laptop to enter LCD built-in self-test (BIST) mode. Continue to hold the D key until the computer boots up.
- The screen displays solid colors and change colors on the entire screen to white, black, red, green, and blue twice.
- Then it displays the colors white, black, and red.
- Carefully inspect the screen for abnormalities (any lines, fuzzy color, or distortion on the screen).
- At the end of the last solid color (red), the computer shuts down.

**NOTE:** Dell SupportAssist Preboot diagnostics upon launch initiates an LCD BIST first, expecting a user intervention to confirm functionality of the LCD.

# System-diagnostic lights

This section lists the system-diagnostic lights of your Inspiron 16 5645.

**Table 37. System-diagnostic lights**

Blinking pattern		Problem description
Amber	White	
1	1	TPM detection failure
1	2	Unrecoverable SPI Flash Failure
1	3	Short in hinge cable tripped OCP1
1	4	Short in hinge cable tripped OCP2
1	5	EC unable to program i-Fuse
1	6	Generic catch-all for ungraceful EC code flow errors
1	7	Non-RPMC Flash on Boot Guard fused system
1	8	Chipset "Catastrophic Error" signal has tripped
2	1	CPU failure
2	2	System board failure (included BIOS corruption or ROM error)
2	3	No memory or RAM detected
2	4	Memory or RAM failure
2	5	Invalid memory installed
2	6	System board or Chipset Error
2	7	LCD failure (SBIOS message)
2	8	LCD failure (EC detection of power rail failure)
3	2	PCI or Video card or chip failure
3	3	BIOS Recovery image not found
3	4	BIOS Recovery image found but invalid
3	5	Power rail failure
3	6	Flash corruption is detected by SBIOS.
3	7	Timeout waiting on ME to reply to HECI message.

**NOTE:** Blinking 3-3-3 LEDs on Lock LED (Caps-Lock or Num Lock), Power button LED (without Fingerprint reader), and Diagnostic LED indicates failure to provide input during LCD panel test on Dell SupportAssist Preboot System Performance. Check diagnostics.

## Recovering the operating system

When your computer is unable to boot to the operating system even after repeated attempts, it automatically starts Dell SupportAssist OS Recovery.

Dell SupportAssist OS Recovery is a stand-alone tool that is preinstalled in all Dell computers that are installed with the Windows operating system. It consists of tools to diagnose and troubleshoot issues that may occur before your computer boots to the operating system. It enables you to diagnose hardware issues, repair your computer, back up your files, or restore your computer to its factory state.

You can also download it from the Dell Support website to troubleshoot and fix your computer when it fails to boot into their primary operating system due to software or hardware failures.

For more information about the Dell SupportAssist OS Recovery, see *Dell SupportAssist OS Recovery User's Guide* at [Serviceability Tools at the Dell Support Site](#). Click **SupportAssist** and then, click **SupportAssist OS Recovery**.

## Real-Time Clock (RTC Reset)

The Real Time Clock (RTC) reset function allows you or the service technician to recover Dell computers from No POST/No Power/No Boot situations. The legacy jumper enabled RTC reset has been retired on these models.

Start the RTC reset with the computer powered off and connected to AC power. Press and hold the power button for thirty (30) seconds. The computer RTC Reset occurs after you release the power button.

## Backup media and recovery options

It is recommended to create a recovery drive to troubleshoot and fix problems that may occur with Windows. Dell proposes multiple options for recovering the Windows operating system on your Dell computer. For more information, see [Dell Windows Backup Media and Recovery Options](#).

## Wi-Fi power cycle

### About this task

If your computer is unable to access the Internet due to Wi-Fi connectivity issues a Wi-Fi power cycle procedure may be performed. The following procedure provides the instructions on how to conduct a Wi-Fi power cycle:

 **NOTE:** Some Internet Service Providers (ISPs) provide a modem or router combo device.

### Steps

1. Turn off your computer.
2. Turn off the modem.
3. Turn off the wireless router.
4. Wait for 30 seconds.
5. Turn on the wireless router.
6. Turn on the modem.
7. Turn on your computer.

## Drain residual flea power (perform hard reset)

### About this task

Flea power is the residual static electricity that remains in the computer even after it has been powered off and the battery is removed.

For your safety, and to protect the sensitive electronic components in your computer, you are requested to drain residual flea power before removing or replacing any components in your computer.

Draining residual flea power, also known as a performing a "hard reset," is also a common troubleshooting step if your computer does not turn on or boot into the operating system.

Perform the following steps to drain the residual flea power:

## Steps

1. Turn off your computer.
2. Disconnect the power adapter from your computer.
3. Remove the base cover.
4. Remove the battery.



**CAUTION:** The battery is a Field Replaceable Unit (FRU) and the removal/installation is intended for authorized service technicians only.

5. Press and hold the power button for 20 seconds to drain the flea power.
6. Install the battery.
7. Install the base cover.
8. Connect the power adapter to your computer.
9. Turn on your computer.



**NOTE:** For more information about performing a hard reset, search in the Knowledge Base Resource at [Dell Support Site](#).

# Getting help and contacting Dell Technologies

## Self-help resources


You can get information and help on Dell Technologies products and services using these self-help resources:


**Table 38. Self-help resources**

Self-help resources	Resource location
Information about Dell Technologies products and services	<a href="#">Dell Site</a>
Contact Support	In Windows search, type <code>Contact Support</code> , and press Enter.
Online help for operating system	<a href="#">Windows Support Site</a>
Access top solutions, diagnostics, drivers and downloads, and learn more about your computer through videos, manuals, and documents.	Your Dell Technologies computer is uniquely identified using a Service Tag or Express Service Code. To view relevant support resources for your Dell Technologies computer, enter the Service Tag or Express Service Code at <a href="#">Dell Support Site</a> .  For more information about how to find the Service Tag for your computer, see <a href="#">Instructions on how to find your Service Tag or Serial Number</a> .
Dell Technologies knowledge base articles	<ol style="list-style-type: none"> <li>1. Go to <a href="#">Dell Support Site</a>.</li> <li>2. On the menu bar at the top of the Support page, select <b>Support &gt; Support Library</b>.</li> <li>3. In the Search field on the Support Library page, type the keyword, topic, or model number, and then click or tap the search icon to view the related articles.</li> </ol>

## Contacting Dell Technologies

To contact Dell Technologies for sales, technical support, or customer service issues, see [Contact Support at Dell Support Site](#).

 **NOTE:** Availability of the services may vary depending on the country or region, and product.

 **NOTE:** If you do not have an active Internet connection, you can find contact information about your purchase invoice, packing slip, bill, or Dell Technologies product catalog.